



Bay Isle Pointe
Homeowners' Association
3195 Mecartney Road
Alameda, CA 94502
T 510-865-3363 F 510-522-1436

BAY ISLE POINTE ASSOCIATION

**ARCHITECTURAL
&
LANDSCAPE
GUIDELINES**

2025

**Adopted: 2020
Inclusive of all amendments
as of November 2024**

Bay Isle Pointe Homeowners Association

**ARCHITECTURAL STANDARDS, RULES &
LANDSCAPE GUIDELINES 2025**

TABLE OF CONTENTS

PART 1 – ADMINISTRATIVE..... 1

- General 1
- CC&R Compliance: 1
- Community & Project Architectural Standards:..... 1
- Architectural & Landscape Improvements – Application Process: 2

PART 2 - BUILDING EXTERIOR MODIFICATIONS..... 3

- Approval Requirements 3
- Additions to Dwellings: 3
 - Ground Level Additions & Extensions: 3
 - Second Story Additions, Extensions, Balconies & Decks..... 3
 - Third Story Room Additions: 3
- Address Numbers..... 3
- Air Conditioners & Condensing Units: 3
- Antenna, Cable TV & Satellite Dish Installations: 4
- Atriums..... 4
- Attic Ventilation:..... 4
- Awnings & Exterior Sun Shades: 4
- Doors (Front Entry)..... 4
- Garages & Vehicle Storage 5
 - Vehicle Parking:..... 5
 - Electric Vehicle Charging: 5
- Garage Doors..... 5
- Gutters & Downspouts:..... 5
- Lights (Attached to House): 6
- Paint (Exterior) 6
 - Color Schemes & Palettes: 6

Paint Gloss Categories:	6
Painting of Building Components:	7
Roofing:.....	7
Materials:	8
Structural Integrity.....	8
Installation:.....	8
Gutters & Downspouts:	8
Metal Roof Vents:	8
Roof Metals (Painting).....	9
Security Systems:.....	9
Shade Structures, Temporary.....	9
Siding & Trim:.....	9
Signs:.....	9
Skylights.....	10
Solar Energy Systems	10
Solariums & Sunrooms:.....	10
Utilities (Boxes, Panels, Wires, Cables, Conduit & Piping)	11
Zero-Lot-Line Walls.....	11
Gas & Electric Meters:	11
Gas Line Outdoor Extensions:	11
Ventilation Devices:	11
Kitchen Exhaust Vents at Zero-Lot-Line Walls.....	11
Windows & Sliding Patio Doors:	12
PART 3 - OUTDOOR YARD STRUCTURES & ACCESSORIES.....	13
Approval Requirements	13
Animal (Pet) Shelters:.....	13
Arbors	13
Barbecues, Grills & Outdoor Kitchens.....	13
Basketball Standards & Recreation Equipment.....	13
Benches:	14
Clearance Requirements	14
Clothes Drying Facilities:	14
Decks at Grade	15
Decks at Lagoon Lots.....	15
Docks.....	15
Fences, Wrought Iron	16
Fences & Gates, Wood.....	16

Fence Extensions:.....	16
Fire Pits & Outdoor Gas & Wood-burning Appliances:	17
Firewood:	17
Flags & Flagpoles.....	17
Garbage, Recycling & Green Waste Bins:	17
Gazebos & Pavilions:	18
Generators, Standby Residential	18
Insect Traps (Electronic).....	18
Lights (Affixed to Yard Structures)	18
Mailboxes:	18
Mailbox Posts:.....	18
Patio Furniture:.....	19
Radiant Heaters:	19
Sheds:.....	19
Spas & Hot Tubs	19
Speaker systems:.....	20
Trellises:.....	20
Weather Vanes	20
Wind Chimes:.....	20
PART 4 - LANDSCAPE & HARDSCAPE IMPROVEMENTS	21
Approval Requirements	21
Bark & Mulch:.....	21
Composting.....	21
Drainage	21
Drought Tolerant Landscaping.....	21
Driveways:.....	21
Hardscape.....	22
Hardscape at Lagoon Lots:.....	22
Lighting (Low-voltage Accent).....	22
Maintenance:.....	22
Patios:	23
Planter Boxes & Flower Containers:	23
Rock Gardens	23
Synthetic Turf	23
Architectural Applications:	23
Submittals	23
Application of Existing Rules/Standards	24

Contractor Qualifications	24
Synthetic Turf Minimum Standards	24
Installation:.....	25
Maintenance:	26
Warranty	26
Tree Installations:	26
Vegetable Gardens	26
Walkways:	26
ABBREVIATIONS & PHRASES.....	27
GLOSSARY OF TERMS (Partial List)	28
AMENDMENTS	29
EXHIBITS	30
Exhibit “A” – Architectural & Landscape Approval Process	
Exhibit “B” – Garage Doors	
Exhibit “B-1” – Garage Door Alternate Styles	
Exhibit “C” – Gutters & Downspouts	
Exhibit “D” – House Painting Detail Guide	
Exhibit “E” – Roofing Materials & Rake Detail	
Exhibit “F” – Window Replacement Installation Details	
Exhibit “G” – Standard Fences & Gates	
Exhibit “G-1” – Fence Detail at Zero-Lot-Line Walls	
Exhibit “H” – Fences with Lattice Extensions	
Exhibit “J” – Mailbox Post Detail & Approved Mailbox	
Exhibit “K” – Deck & Patio Setbacks for Lagoon Lots	

Bay Isle Pointe Homeowners' Association

ARCHITECTURAL STANDARDS, RULES & LANDSCAPE GUIDELINES 2025

PART 1 – ADMINISTRATIVE

General:

The Bay Isle Pointe Homeowner Association's *Architectural Standards, Rules & Landscape Guidelines* (hereinafter referred to as "BIP Architectural Standards"), were developed to maintain Bay Isle Pointe's harmonious design and to preserve the property values of all homes. The Bay Isle Pointe Homeowners' Association consists of two project developments: Bay Isle Pointe and Victoria Bay. Consequently, the BIP Architectural Standards may differ somewhat between the two projects regarding exterior details, materials, and other requirements.

CC&R Compliance:

When you, the "Owner", purchased your home, you took title to your "Lot" subject to all restrictions, easements, rules, etc., recorded on your Lot as set forth in your Policy of Title Insurance. You also took title to your Lot subject to all of the provisions set forth in the *Declaration of Covenants, Conditions and Restrictions* (CC&R's) recorded on your property as set forth by both the Community of Harbor Bay Isle Owners Association (hereinafter referred to as 'CHBI' or 'Community'), and the Bay Isle Pointe Homeowners' Association (hereinafter referred to as 'BIP' or 'Project').

The CC&R's provide for *architectural review* through the Community Architectural Committee (CAC), and the Project Architectural Committee (PAC) for Bay Isle Pointe. While the PAC and CAC review exterior improvements for conformance to architectural guidelines, it is both the Community and Project Boards of Directors that enforce the CC&R's and Architectural Standards to maintain the appearance of BIP and other Community neighborhoods. These two boards may assess fines, after opportunity for public hearing, to homeowners who violate the CC&Rs and/or the Architectural Standards. Furthermore, *unapproved* installations may be subject to corrective measures or replacement of the non-conforming construction work at the homeowner's expense.

Community & Project Architectural Standards:

Owners should also review the Community's *Architectural Rules, Standards and Plant Guidelines* (hereinafter referred to as 'Community Architectural Rules'), for specific requirements that apply to proposed property improvements. The Community Architectural Rules have been adopted by the Bay Isle Pointe Homeowners' Association, and shall be used in conjunction with the BIP Architectural Standards. Refer to the Community Architectural Rules section entitled "administrative" for requirements not contained under "PART 1 - ADMINISTRATIVE" herein.

Where the BIP Architectural Standards are more restrictive than the Community Architectural Rules, the BIP Standards shall prevail. Where certain provisions and requirements are not addressed in the BIP Architectural Standards, the Community Architectural Rules shall apply as though completely contained herein. Where applicable the BIP Architectural Standards may reference specific sections of the Community Architectural Rules that apply and/or augment the BIP Architectural Standards.

Architectural & Landscape Improvements – Application Process:

The Community and Project CC&R's require that an "architectural application" be submitted to the Community offices for *all* exterior improvements to dwellings and exterior yard areas. Improvements are defined as "all improvements/repairs to exterior surfaces of the house, including repainting, any building modifications, and all improvements to the land including landscape, hardscape, or any structural additions to the "land". For telecommunication installations (e.g., antenna, mast, cable TV, and satellite dish) a special Community form entitled "*Satellite Dish / Antenna / Cable Installation Form*" is required for approval in lieu of the standard architectural application.

Architectural applications are available at the Community offices and on the CHBI website at www.harborbay.org. Applications should include drawings, photos, cut sheets, and any supporting documents to assist the Project and Community architectural committees (PAC/CAC), in reviewing the proposed improvements. Written approval from the Community association office is required before the Homeowner may begin any construction work.

The standard application process may take 3 to 4 weeks for review, processing, and approval. Incomplete applications may require resubmission to the Community offices and additional time. The Community Architectural Committee's meeting schedule can be found on the CHBI website. The Community's Architectural Administrator and staff are available to assist homeowners with completing the application, and to plan the review process scheduling.

Homeowners are encouraged to provide their contractor with a copy of the CHBI application *approval* letter to confirm that the approved construction materials and products are those contained in the owner/contractor agreement. Verification of the *installed* construction improvements (specified materials and products), may be required from the homeowner during the PAC's final inspection. Refer to Exhibit "A" – Architectural & Landscape Approval Process, for a flow diagram of the approval process.

PART 2 - BUILDING EXTERIOR MODIFICATIONS

Approval Requirements:

All proposed building modifications require the submission and approval of an architectural application prior to the commencement of any property improvement work.

Additions to Dwellings:

All new room additions or extensions impacting the exterior of existing dwellings shall be wood frame construction to match the existing house, and shall be harmonious with the architectural character of the dwelling. Exterior finish materials, colors and details, such as roofing, siding, doors/windows, eave overhangs, and architectural trim of the proposed addition or extension must match those of the existing dwelling. Refer to similar sections of the Community Architectural Rules for CAC approval criteria and other requirements not contained herein.

Ground Level Additions & Extensions:

Proposed room additions and building extensions such as roofed porches and outdoor kitchen enclosures will be considered on a case-by-case basis, subject to the original BIP project development agreements with the City of Alameda for lot coverage, open space and building setback requirements. Ground level additions and extensions must be architecturally integral in design, materials and colors with the existing structure to which they are attached as if constructed with the original house. Open-walled, screened and/or glass enclosed patio covers with non-approved roofing material (e.g., metal, plastic, fabric, etc.), and of post and beam construction are not permitted.

Second Story Additions, Extensions, Balconies & Decks:

Second story architectural appendages will be considered on a case-by-case basis. Evaluation considerations may include, but not be limited to, design integration with the existing structure, appearance and visual impacts on the neighborhood, retention of adjacent neighbors' privacy and views, and compliance with required setbacks and lot coverage as applicable.

Third Story Room Additions:

Third story room additions and/or attic conversions are prohibited.

Address Numbers:

Numbers may be polished brass, antique brass or wood with size and white color to match the original numbers. Brown, dark green or black plates behind numbers are allowed. Numbers must be attached to the house except in cases where the numbers would not be visible from the street if attached to the house. In these cases numbers on a plain rigid backing may be mounted on a stake (post) and placed in a visible location. Ceramic tiles and plastic numbers are not allowed. Illuminated address signs similar to those in the Victoria Bay development *are* allowed in other areas of Bay Isle Pointe.

Address numbers shall be readily visible from the public street by emergency responders during both day and night hours (per City of Alameda ordinance), unobstructed by trees, shrubs or other vegetation. Homeowners shall be responsible for trimming all vegetation that obscures public view of their dwelling's address number. It is recommended that all house address numbers be illuminated with an adjacent exterior light fixture to enable visibility after dark.

Air Conditioners & Condensing Units:

Remote condensing units for air conditioner (AC) furnaces are only allowed in rear or side yard locations, and must be visually concealed from neighboring properties to every extent practicable. The condensing units shall be mounted on a concrete slab and away from existing

windows and walls per Code, and per the unit manufacturer's installation requirements. The sound level of the unit shall not unreasonably impact adjacent neighbors. Refer to sections entitled 'Utilities' in PART 2, and 'Clearance Requirements' in PART 3, for additional information not contained herein. Visible window-mounted, self-contained air conditioning units are not permitted.

Remote condensing units (e.g. AC compressors, heat pumps, etc. located outside) shall have a manufacturer's published "operating" sound rating not to exceed 55 dBA.

Antenna, Cable TV & Satellite Dish Installations:

All telecommunications equipment attached to the exterior of a dwelling shall comply with the Community Architectural Rules. Owners are encouraged to install antennas, masts and satellite dish antennas in locations that are *not* visible from a public way (e.g., streets, sidewalks, parks, lagoon paths, etc.) and *not* placed in locations that would visually impact neighboring properties. Particular attention must be given to eave/wall locations on zero-lot-line walls that are adjacent to a neighbor's front entrance or rear yard area. Such locations are strongly *discouraged*. Homeowners are encouraged to work with their telecommunications contractor to optimize *best* equipment locations that reduce visual impacts.

To the extent feasible all exposed cables, wires and boxes shall be minimized and installed per section entitled "Utilities" in PART 2. Equipment and hardware such as dish antennas, masts, mounting brackets, and such shall have a gray factory finish (often referred to as "utility" gray). White-colored equipment is discouraged and should be minimized to every extent possible. Top of equipment masts should not exceed 4 feet above the exterior surface on which they are mounted. Small, low-profile repeater masts used in mesh network systems should be used whenever possible.

The Community's "*Satellite Dish / Antenna / Cable Installation Form*", must be submitted and approved prior to the telecommunication equipment being installed. The homeowner should also provide a copy of the Installation Form to their contractor before the installation of any telecommunication equipment. A final inspection is required after the installation.

Atriums:

In the one-story "Fostoria" and "Steuben" floor plans interior atriums containing bedroom windows shall not be enclosed with a roof (or roof with skylights), or otherwise partially covered by arbors, canopies, lattice, or other permanent or temporary coverings. Atriums must remain "open, uncovered space, unobstructed to the sky" per Code to provide legal (secondary) emergency egress from adjacent bedrooms.

Attic Ventilation:

Supplemental attic ventilation devices such as low profile sheet metal roof vents shall be unobtrusive and compatible in design with the existing structure. Roof vents shall be painted to match the roof and other painted exhaust/plumbing vents. Sheet metal wind turbines and *high profile* sheet metal louvered vents are not permitted.

Awnings & Exterior Sun Shades:

Exterior fixed awnings, retractable awnings (canopies), and other sun shading devices attached to exterior walls of dwellings are not permitted.

Doors (Front Entry):

Front entry doors may be refinished or replaced with wood doors of similar design and size as the original installed doors. Fiberglass and metal doors may be approved if they are of a similar design to the original raised panel doors and are painted or have a factory stain finish. Doors may be painted with the approved siding, trim or accent color of the dwelling or other color as approved. Bright, primary colors (red, yellow, orange, blue, etc.) are not allowed. Otherwise, existing or new wood replacement doors shall be finished in warm natural wood tones. All new non-standard or custom

replacement doors and colors shall be considered on a case-by-case basis. Custom wood doors may be comprised of raised panels in a variety of configurations and styles, and may incorporate glass lights (windows). Front entrance screen doors or storm doors are not permitted.

Garages & Vehicle Storage:

Owners are urged to keep their garage doors closed except when entering and exiting the garage, or when engaged in garage and front yard activities, to maintain the attractive appearance of the neighborhood, and to reduce the possibility of unlawful entry and theft from garages (or houses) due to garage doors being left open and unattended.

Vehicle Parking:

Residents are encouraged to park their vehicles within their garage. When not parked in the garage, operating vehicles may only be parked in the driveway area at the front of the house, and not on any other portion of the lot. At no time is a *non-operating* vehicle to be stored in the house driveway for a period of time exceeding thirty (30) days. Refer to BIP CC&R Article 2, Paragraph 2.3 – “Parking and Use of Motor Vehicles”, for requirements not contained herein.

Electric Vehicle Charging:

Vehicle charging stations shall be located within the garage such that charging cords can reach electric vehicles parked in the garage or in the driveway. Charging stations, cords and other accessory equipment at *exterior* locations may be considered on a case-by-case basis, if the proposed location will have minimal visual impact to neighbors or from the adjacent public street.

Garage Doors:

Garage replacement doors shall be wood or metal sectional overhead doors of the same size as the original door. Metal overhead doors shall have a wood-textured appearance and a style compatible with the dwelling. Replacement doors must be painted with the same paint as the house to exactly match the siding or trim color and sheen. Two-color garage doors are not permitted. Unpainted doors with exposed factory finish are not allowed. When a new garage door is installed where the house is *not* currently being repainted, the new garage door must be painted to match either the siding or trim color within sixty (60) days of installation.

Garage doors may have windows across the top row of panels in a standard four-row raised-panel overhead door with rectangular panels, one window in place of each panel. Windows shall have frosted or obscure glass, one piece without divided panes. Clear glass is not allowed. Refer to Exhibit “B” – Garage Doors, for standard garage doors (e.g. insulated metal with sixteen raised panels), and those with windows. For additional approved door styles and configurations refer to Exhibit “B-1” – Garage Door Alternate Styles.

Gutters & Downspouts:

Replacement gutters and downspouts may be fabricated from aluminum or galvanized steel. Gutters must be of equal size and resemble the curved fascia style originally installed, or may be straight fascia gutters with one, two, or three horizontal ribs unless otherwise approved by the Community Architectural Committee. Gutters must be painted using the same paint as the trim paint to exactly match the trim color (or fascia paint if a third accent color is used). All gutters with a factory-applied coating must be finished with house paint. Downspouts must be painted using the same paint as the house surface against which they rest to exactly match siding, trim, or fascia paint, regardless of whether unpainted galvanized or factory painted extruded aluminum is used. In areas where downspouts pass in front of bricks, the color shall remain that of the house siding. When new gutters and downspouts are installed on a house

that is *not* being repainted, they must be painted within sixty (60) days of installation. Refer to Exhibit “C” – Gutters & Downspouts, for approved gutter profiles and information. Downspouts shall be connected to existing underground drain lines installed by the original developer.

Lights (Attached to House):

Replacement decorative exterior light fixtures shall be similar in general size, shape, materials, and finish to the original fixtures, and shall be compatible with the design and style of the house. Proposed light fixtures may consist of glass and metal with a brass, antique brass, black or other finish in various design configurations, and will be considered on a case-by-case basis.

Unshielded spotlights or flashing lights are prohibited. Security lights must be shielded and used for emergencies only. Motion detectors are permitted provided the lights are shielded from public view and do not create an annoyance. Light from exterior fixtures shall not intrude into neighboring properties. No colored bulbs are allowed in light fixtures, including landscape lighting, with the exception of Holiday Season lights during specified times. Holiday multicolored, decorative lights in front yards and on houses are only allowed to be installed each year after November 20th, and must be removed by January 31st in the following year. Cascading white or colored mini-bulbs and rope lights are considered seasonal lights and are governed by this rule. Refer to the Community Architectural Rules for additional requirements not contained herein.

Paint (Exterior):

Exterior color schemes for homes in Bay Isle Pointe shall maintain the visual character and harmony of the neighborhood. Before any painting work is started, an architectural application for repainting must be filed by the homeowner with the Community offices. Applications must be approved by the CAC prior to start of any work. Painting applications may include repairs to and/or replacement of wood siding and trim, like for like, caused by dry rot or other deterioration as part of the application. For general siding and trim information, material substitutions, and whole-house siding replacement refer to section entitled “Siding & Trim” in PART 2.

Color Schemes & Palettes:

Bay Isle Pointe’s newest exterior paint palette is based on Kelly Moore Paints (KM) standard colors. Should a homeowner purchase paint from a different manufacturer, that manufacturer must match the approved KM paint colors. The selected color scheme must be different from the immediate neighboring houses on all adjacent properties, and those directly across the street. Substitution of colors within an individual scheme is not allowed. The developer paint color schemes have been discontinued and may no longer be used. All of the available color schemes are included in the Color Paint Binder (palette) including color samples. Homeowners may choose from any of these approved color schemes, except as noted. Color Paint Binders may be viewed at the Community offices during regular business hours. The approved BIP KM paint palette is also available on line at www.harborbay.org. No color changes are permitted after the color scheme has been approved unless such changes are resubmitted and approved.

Bay Isle Pointe prefers that homeowners select from the approved color palette. An owner may propose and submit an alternate color scheme using colors from Kelly Moore or another manufacturer. Alternate color schemes are subject to review and approval by the CAC and the BIP Board of Directors. If a homeowner chooses this option, three (3) paint chips of each color must be provided with the architectural application.

Paint Gloss Categories:

Exterior house components shall be painted using the following paint sheen categories. Refer to Exhibit “D” - House Painting Detail Guide, for locations of siding (main), trim and

accent colors from the paint palette.

Siding (Main) Color: Flat, Low Sheen or Eggshell
Trim and Accent Color: Low Sheen, Eggshell or Satin
Front Entry Doors: Satin or Semi-Gloss
High Gloss: Not allowed on any surface

Painting of Building Components:

The color schemes are specific to siding, trim and fascia. *Siding* colors may only be used for siding; *trim* colors only for door/window and horizontal trim (and exterior features like 4x outriggers and window boxes); and *accent* colors only for fascia boards at roof gables and eaves. The exception is the front door which may be stained with a clear finish.

1. Front entry and doors are preferred to be stained in a natural wood tone, but may be painted to match the approved siding, trim or accent color of the house color scheme. Front entry doors shall be painted or stained one (1) color only. Refer to section entitled "Doors (Front Entry)" in PART 2, for painting requirements not contained herein.
2. French (and sliding French) doors, may be stained in a natural wood tone, or painted with the same paint and color as the siding or trim color. Refer to section entitled "Doors (Front Entry)" in PART 2, for painting requirements not contained herein.
3. Garage doors shall be painted to match the siding or trim color, and must be painted one (1) color only using the house paint. Factory-finish colors are not allowed regardless of how close the factory color may be to the siding or trim color. Refer to section entitled "Garage Doors" in PART 2, for requirements not contained herein.
4. All exposed metal attached to the house including, but not limited to, louvered vents, gutters, downspouts, meters, utility boxes and piping, etc., shall be painted to match the color of the surface to which they are attached. Refer to section entitled "Gutters & Downspouts" in Part 2, for painting requirements not contained herein.
5. All exposed metal roof flashing next to wood surfaces must be painted with the same paint color as the adjacent trim, siding, or fascia color. All exposed metal roof jacks, flues, diverters, vent pipes and other similar items within the roof area shall be painted to closely match the color of the roof.
6. Chimney cap flashing covering the top of the chimney shall be painted the adjacent trim color. Metal spark arrestors and gas fireplace insert vents shall be painted the trim, siding or roof color, whichever is darker. Lighter colors are discouraged.

Roofing:

Existing wood shake roofs shall be maintained in good condition, and may have minor repairs made to them without an architectural application. Otherwise, the homeowner must have an approved architectural application from the Community Architectural Committee (CAC) *prior* to demolition or installation of any new roofing material. All applications for re-roofing must state whether or not the gutters and/or downspouts will be replaced with the re-roofing work. The homeowner must obtain a building permit for re-roofing from the City of Alameda prior to the start of any related work. A re-roofing *final inspection* must be requested by the homeowner within forty-five (45) days from completion of the roofing work.

Materials:

With the adoption of a revised roofing ordinance, the City of Alameda now requires that all residential roofing have a “Class A” fire resistant rating. To achieve the Class A fire rating using wood shakes, the wood shakes must now be *fire-retardant* treated, and installed over an approved fire-resistive underlayment system. Because of the added expense of this Class A shake roof assembly, alternate roof replacement materials were considered and selected to retain the original wood shake appearance with deep shadow lines and textures. Two product lines of composition fiberglass-asphalt shingles were selected for their deep shadows and high-texture profiles. These *architectural series* materials achieve the look, performance, and longevity of wood shakes. The pre- approved roofing materials to be installed must be one of the following:

1. Cedar Wood Shakes: Class A fire-rated roof system comprised of fire-retardant treated cedar wood shakes, hand split with $\frac{3}{4}$ ” minimum thickness, installed over an approved fire-resistant underlayment, and approved by the City of Alameda. Please be advised that insurance companies may no longer insure homes with wooden roofs.
2. Fiberglass-Asphalt Composition Shingles:
 - a. CertainTeed Landmark TL triple-layer dimensional shingles, Country Grey color.
 - b. GAF Timberline Ultra HD (*Ultra High Definition*) multi-layered shingles, Weathered Wood color. (NOTE: Other GAF ‘Timberline’ series shingles are not allowed).

Other roofing materials are discouraged, but may be considered on a case-by-case basis with supporting documentation in the architectural application. Be advised that the lifetime rating on some products may be lower than the recommended options above.

Structural Integrity:

When considering roofing materials other than those listed, the homeowner shall be responsible for ascertaining from a professional (structural) engineer that the owner’s roof *structure* will support the weight of the proposed roof assembly. Fiber-cement and other composite roofing products can weigh substantially more than the originally installed roofs. Approval of any roofing system by the CAC is *not* an approval or acceptance of the house roof support framing on which the new roofing is to be installed.

Installation:

Refer to Exhibit “E” – Roofing Materials & Rake Detail, for general information and acceptable roof installation detail of the roofing at the gable roof edge. Shaped roof tiles or composite shingles that wrap the edge of the roof rake and cover part of the fascia, are not allowed. Refer to paragraph entitled “Roof Metals (Painting)” in this section, for painting of metal roof penetrations and metal flashings at roof edges.

Gutters & Downspouts:

New gutters may be curved fascia gutters of equal size as the original gutters, or straight fascia gutters with one to three horizontal reinforcement ribs unless otherwise approved by an Architectural Committee. Refer to Exhibit “C” – Gutters & Downspouts, for gutter profiles. Refer to section entitled “Gutters & Downspouts” in PART 2, for painting requirements not contained herein.

Metal Roof Vents:

Refer to section entitled “Attic Ventilation” in PART 2, for metal roof vent requirements not contained herein.

Roof Metals (Painting):

All roof metals (flashing, diverters, vents, pipes, flues, etc.) must be painted to match the roof color. Roof edge flashings, if any, shall be painted to match the adjacent rake or gutter fascia color. Refer to section entitled "Paint (Exterior)" in PART 2, for requirements not contained herein.

Security Systems:

Security system devices and equipment should be as unobtrusive as possible and takes into consideration their purpose and location. Security lights must be shielded and used for emergencies only. Motion detectors are permitted provided the lights are shielded from public view and their operation does not create an annoyance.

Shade Structures, Temporary:

Refer to similar section in the Community Architectural Rules for requirements.

Siding & Trim:

Refer to Community Architectural Rules for requirements not contained herein. For *partial* siding and trim repairs replacement materials must match the original installation. Siding products of redwood, cedar, shingle panels and hardboard composition shall match existing siding materials, profiles and wood textures. Siding manufactured from metal, fiberglass, vinyl, or similar composite material is prohibited. Wood trim shall be decay-resistant 2x rough or saw- textured wood (pre-primed recommended) to match existing sizes.

Where siding and trim disrepair is extensive and requires the entire house (whole-house) or one entire wall to be replaced, fiber-cement siding products may be used, and shall match the existing siding and trim profiles and textures as close as possible. Where only *one wall* of siding is replaced with fiber-cement siding, any visual differences between existing siding and the fiber-cement siding shall not be noticeable when viewed from the closest adjacent street. Horizontal siding courses between the two materials shall match at the house corners. Where *whole-house* siding replacement is proposed with substantial exterior design modifications such as a change in siding direction (vertical to horizontal), removal of 4x outriggers, belly bands, or other architectural design elements, the architectural application shall contain design drawings (exterior elevations, renderings, sketches, etc.) that illustrate the proposed *new* exterior design of the house. If pre-finished (pre-colored) fiber cement siding is used, the proposed colors must closely match one of the paint schemes in the BIP color palette. Refer to section entitled "Paint (Exterior)" in Part 2, for painting information not contained herein.

If fiber-cement window trim is used, ensure that the trim material is thick enough to extend beyond, or be flush with, adjacent window frames. Typically, fiber cement siding trim is only 1" thick (as manufactured by James Hardie, for example), and may not be thick enough to cover the edge of the window frame. Fiber cement siding manufactured by Allura offers trim in a full 1- 1/2" thickness that matches the existing 2x wood trim size. Refer to Exhibit "F" - Window Replacement Installation Details, and to section entitled "Windows & Sliding Patio Doors" in PART 2, for information and requirements not contained herein.

Signs:

Contractor signs for remodeling, painting, roofing, etc., are not permitted on private property or in CHBI Common areas. Homeowners are responsible for their contractors' compliance with this rule. Real estate signs are permitted to be installed in windows or on standard real estate posts set in the ground on private property. These signs shall be a maximum of 18" x 24", displaying the words "for rent" or "for sale" with the agent's name and telephone number. A maximum of one sign per home may be displayed, except on lagoon lots where a second sign may be

displayed on the lagoon side. Political signs are permitted 30 days before an election, but must be removed within 5 days following the election date. Posting signs in CHBI common areas is prohibited. Refer to Community Architectural Rules for sign compliance not contained herein.

Skylights:

Skylights are permitted provided they are compatible with the existing structure and do not unduly impact the dwelling's appearance when viewed from the street, or other public ways such as sidewalks and paths. Skylights shall be flat, and dark in color to blend in with the existing house roof. Clear or white translucent acrylic 'dome' skylights are not allowed. Solar tube skylights will be considered on a case-by-case basis depending on size, number, and visibility from public ways. Solar tubes shall have low profile flashing that slopes with the roof pitch (parallel to the roof), to reduce the overall height. Refer to the Community Architectural Rules for requirements not contained herein.

Solar Energy Systems:

Solar energy systems that produce electricity using photovoltaic (PV) panels are allowed if the panels are visually compatible with the house and roof design, and are concealed from public view to every extent feasible. Solar collectors/panels must be installed on the roof of the home, and must lay flat on the surface of the roof. Panels shall be dark in color to blend in with the roof, and may not contain any reflective/shiny (bare metal) surfaces. All exposed conduit, panels, electrical boxes and other solar equipment shall be painted to match the surface to which they are attached. Refer to section entitled "Utilities" in PART 2, for information regarding visibility of utility components from public ways.

For solar energy systems with a *battery back-up* option the storage battery units shall be located indoors (usually in the garage) or in the side or rear of the yard behind the fence not visible from a street, path, or lagoon for *all* installations because of their relatively large size. Other wall-mounted solar equipment (e.g., inverters, backup power controller, disconnect switches, inverters, etc.), shall be neatly installed and minimized from public view when located outside near the electric meter. Please note that some manufacturers may integrate an energy storage battery as part of their inverter/solar equipment package and these shall still be considered batteries in terms of their required placement in the home/yard. Particular attention should be given to zero-lot-line walls where a neighbor's front door access may be adjacent to, and in full view of, the applicant's outdoor utility meters and solar equipment.

An architectural application is required for the solar energy system installation, and a final inspection must be completed after installation. All solar system components (solar panels, roof and wall-mounted equipment and utilities), and their locations, shall be indicated in the application. A diagrammatic exterior elevation drawing showing the electric meter and adjacent solar equipment and Google Earth aerial view of the house and proximity is required. Refer to similar sections in the Community Architectural Rules for requirements not contained herein.

Solariums & Sunrooms:

Solariums and sunrooms are defined as pre-fabricated metal and glass enclosed rooms with painted (or anodized) metal framing members (usually aluminum), glass roof (or roof to match the existing house), and side wall panels, on a concrete slab foundation attached to a house. Solariums are considered additions to an existing dwelling, and are subject to the City of Alameda zoning ordinance setbacks and site coverage requirements. Solariums and sunrooms larger than 12' x 15' are not permitted, and shall be located in rear or side yards out of public view. Reflective or mirrored glass is not permitted. Solariums are not to be considered for use as bedrooms. Proposed solariums/sunrooms will be considered on a case-by-case basis. All applications for a solarium/sunroom addition must include the following:

1. Site plan drawing showing the location and size of the solarium in relation to the house, fence and lot lines drawn to scale.
2. Elevation view of the house wall to which the solarium/sunroom will be attached, and one side view.
3. Complete and legible manufacturer's cut sheets and/or brochure of the solarium/sunroom proposed, including design, color, dimensions, materials and details, including the window and doors to be used therein.

Utilities (Boxes, Panels, Wires, Cables, Conduit & Piping):

Refer to the Community Architectural Rules for utility requirements not contained herein. Utilities including boxes, panels, phone wires, cables, conduit, piping, and solar equipment shall be installed in a manner not visible from public ways or from neighboring properties to every extent feasible. They shall be installed in an unobtrusive, house-compatible and shielded manner (i.e. running under siding, shingles, along trim, etc.), where possible. All exposed utilities shall be painted with the same house paint color and sheen to match the surface to which they are attached or to which they are immediately adjacent.

Zero-Lot-Line Walls:

Particular attention should be given to proposed utilities and equipment located on zero-lot-line walls in full view from a neighbor's front yard street entrance, which could unduly impact that neighbor. Applications for new utilities at these entry areas must fully detail the proposed installation, complete with existing photos of the impacted areas. Where possible, exposed cables/piping should be routed internally through the house using closets for vertical runs and attic areas (for example), and with solar equipment located in garages to every extent possible to reduce visible utilities at these entry locations.

Gas & Electric Meters:

Existing gas and electric meters shall have adequate clearance for access by utility company maintenance personnel. The meter area shall be free of overgrown shrubs that impair access, and which can reduce air circulation leading to increased moisture and premature corrosion of gas piping.

Gas Line Outdoor Extensions:

All natural gas line extensions for outdoor equipment (barbeques and cooking equipment, for example), shall require an architectural application and a plumbing permit from the City of Alameda prior to commencing the work. Outdoor natural gas line installations shall be performed by a contractor currently licensed in the State of California, and listed with the City of Alameda Building Department. The homeowner shall provide documentation that all gas piping work was performed and approved under City of Alameda permit.

Ventilation Devices:

Refer to the Community Architectural Rules for ventilation devices and requirements not contained herein. Where interior wood-burning stoves or gas heaters are installed, stove/heater metal vents protruding above the roof must be painted to match the other roof pipe and vent colors. Where gas fireplace *inserts* are installed, the new insert vent cap at the top of the chimney must be painted to match the house trim, siding or roof color, whichever is darker. Any exterior portion of a stove/heater vent that protrudes through a *side wall* must be boxed in with framing, siding and trim material matching the house, and painted to match the house siding color. All such combustion appliance installations shall require a building permit and must comply with all applicable Codes.

Kitchen Exhaust Vents at Zero-Lot-Line Walls:

Original builder-installed cooking appliances (downdraft cooktops or other units with low cfm exhaust output) are relatively quiet with minimal impacts to adjacent neighbors from

fumes or exhaust noise. Where an existing electric cooking appliance is replaced with a gas range/cooktop and a high-output exhaust hood, and where the exterior exhaust vent is relocated on a zero-lot-line wall, an architectural application shall be required for approval. The application shall include the location of any new exterior vent, and specifications for the range hood, or remote exhaust fan unit, including cfm and sound-rating. Exhaust fans shall be located in the range hood, remotely in an attic or at a second-floor roof. In no case shall the exhaust fan unit be installed on the exterior surface of a zero-lot-line wall that is adjacent to a neighbor's yard. Where practical, cooking exhaust fan vents shall terminate at the roof away from adjacent neighboring yards to reduce noise and fumes. Where cooking exhaust fan vents terminate at zero-lot-line walls, the sound level from such vents shall not be unreasonably noisy and otherwise disturbing to the affected adjacent neighbor. Ensure that interior cooking exhaust fan hoods have adequate internal grease traps to eliminate any grease build-up at exterior wall vents. The impacted neighbor must be made fully aware of the proposed exhaust vent changes, and be satisfied that all feasible mitigation measures have been taken to reduce fumes and exhaust fan noise.

Windows & Sliding Patio Doors:

Refer to Community Architectural Rules for related items and requirements not contained herein. Replacement windows and sliding patio doors shall be energy efficient, industry certified products, and fabricated from aluminum, vinyl, fiberglass, or other composite material. Wood windows shall be clad in aluminum or vinyl with no exposed exterior wood surfaces. Approved window and sliding patio door colors are dark anodized bronze (or the approved equivalent thereof), tan (often called "sand" or "sandstone", for example) and white. With the advent of vinyl, fiberglass, and composite windows there is now a wide range of "dark bronze" look-alikes with no real industry standard in colors and names of colors. Existing windows now vary in color from medium bronze (brown), dark bronze, very dark bronze to almost black, and now "black" as an actual color with some windows companies. These similar colors will be considered as an "approved Equivalent" to the dark anodized bronze color. Replacement windows having a different configuration than the existing windows will be reviewed for design compatibility with the existing house on a case-by-case basis. Casement or awning windows are not allowed on the street side of a house. Any and all windows and sliding patio doors that are visible from a public area must match in color and materials (i.e., cannot replace only the front windows if side or rear windows are publicly visible).

Windows and sliding patio doors shall be installed flush with, or recessed within the inside edge, of the existing window/door trim. No part of the installed window or sliding patio door (except patio door handles), shall protrude beyond the face of the adjacent trim, or cover any part of the existing trim (Refer to Exhibit "F" – Window Replacement Installation Details). New window and sliding patio door trim shall match the existing originally installed 2x wood trim (1-1/2" actual thickness). Where 5/4" nominal thickness (1" actual thickness) fiber-cement window trim is used, ensure that new windows and sliding door frames will not extend beyond the face of the trim. Refer to section entitled "Siding & Trim" in PART 2, for additional requirements. Faded or damaged factory-applied window finishes are to be restored to their original color, or the entire window unit(s) replaced. All applications for window replacement must include the following:

1. The location of the windows and sliding patio doors to be replaced on the house, and the type of window/door operation for each location (include a diagram of the house and photos if possible).
2. A sample of the color proposed for windows/sliding doors and frames.
3. Manufacturer's cut sheets and/or brochure of the windows/doors to be used, including design, dimensions, materials and details of window/door products. Where more than one type of window frame profile detail is shown in the manufacturer's product literature, indicate specifically which window frame detail is being proposed.

PART 3 - OUTDOOR YARD STRUCTURES & ACCESSORIES

Approval Requirements:

All proposed outdoor structures require the submission and approval of an architectural application and plans prior to the commencement of property improvement work.

Animal (Pet) Shelters:

Shelters shall be constructed of materials and colors matching the house or of natural wood. Wire mesh windows, fiberglass or plastic materials are prohibited, except for small bird houses. Pet shelters shall be portable (moveable) and at least 12 inches lower than the fence. Shelters shall not be attached to fences or walls and must be located to avoid noise, odor and other nuisances to neighbors. Shelters shall have a 6-inch minimum clearance from fences and walls, and shall be *moveable* to allow for maintenance at zero-lot-line walls.

Arbors:

An arbor is defined as an overhead structure with posts and open crisscross horizontal framing that allows the filtered passage of sunlight. Arbors shall be constructed of appropriate outdoor natural wood (pressure-treated lumber is not allowed), which shall be left in its natural state or sealed with a clear non-gloss sealer. Free-standing structures not attached to the house may be stained and treated similarly to wood decks. Refer to section entitled "Decks at Grade" in PART

3. Redwood-color stain or paint is prohibited for free-standing structures. Arbors attached to the house, or free-standing and immediately adjacent to the house or eave, may be painted a color matching the house siding or trim. Structures must be set back from the fence as determined on a case-by-case basis, depending on the proximity of neighboring houses, but with a minimum of 6 inches. Structure height over the acceptable standard of 8 feet 6 inches above grade shall be similarly determined. Refer to section entitled "Clearance Requirements" in Part 3, for setbacks from zero-lot-line walls.

Barbecues, Grills & Outdoor Kitchens:

Permanent outdoor barbecues, grills and kitchens utilizing natural gas or propane cooking equipment shall require an architectural application for approval. The application shall include a site plan drawing showing the size and location of all permanent free-standing cooking equipment and outdoor kitchens. Indicate all proposed distances to adjacent existing structures such as fences and zero-lot-line walls. It is recommended that *permanent* outdoor cooking installations be located closer to the main dwelling. Otherwise, free standing grill installations shall be a minimum of 5 feet, or more, from adjacent zero-lot-line house walls depending on the grill/cabinet size, and 3 feet from fences. Provide manufacturer's literature showing size and heights of proposed cooking equipment. All cooking equipment shall have a hinged hood or lid for safety. Open flame, wood-burning barbecues/grills are prohibited.

Permanent and *portable* barbecues/grills (propane, charcoal and wood pellet units), and outdoor kitchens must be located in an area that will not permit smoke to unreasonably intrude into neighboring properties. Where outdoor natural gas line extensions are required for cooking equipment, see section entitled "Utilities", subsection entitled "Gas Line Outdoor Extensions" in PART 2.

Basketball Standards & Recreation Equipment:

Such equipment may not be attached to any structure. Portable basketball standards are permitted for use in accordance with the Community Architectural Rules. Temporary basketball standards shall be free standing from any residential building, fence, or other permanent structure, and must meet the following requirements:

1. Temporary and portable in their use and location.
2. Stored out of view from public ways or neighboring properties.
3. Used only during daylight hours.
4. Used only in driveways, auto courts (shared driveways), or on the auto side of the house, except standards for children no higher than 5 feet may be used in back yards.
5. Used without any additional artificial lights.
6. Used so as not to create a nuisance for any neighbor or other resident.

Recreational equipment and sport apparatus *permanent* installations in rear/side yards, which can be viewed at ground level above the fence (swing sets, for example), are not permitted. All such equipment and apparatus are not permitted in front yards.

Benches:

Permanently *fixed* benches shall be constructed of Redwood, Cedar, or Ipe (Brazilian walnut), earth-tone masonry, concrete or stone, and shall be left natural or treated with clear non-gloss sealer. Wood benches may be approved for painting to match the house paint colors on a case- by-case basis. Refer to section entitled “Clearance Requirements” in PART 3, for setbacks from existing zero-lot-line walls.

Clearance Requirements:

The Bay Isle Pointe CC&R’s provide for five-foot wide maintenance easements next to zero-lot- line walls that form the boundary of an immediate neighbor’s yard. The homeowner with the zero-lot-line wall is granted access to the neighbor’s yard to inspect drainage and earth/wood separation (bottom of siding), and to maintain exterior walls including painting and siding repairs, or complete siding replacement. Access shall mean providing reasonable physical work space (e.g. adequate clearances) for a contractor to conduct such maintenance work between a zero-lot-line wall and any fixed permanent yard structure. The following minimum clearances are required from existing zero-lot-line walls:

1. Patios and walks (concrete, pavers, brick, flagstone, etc.): 3 feet
2. Raised wood decks (maximum 12” above grade): 5 feet
3. Low, short structures (fixed seating, raised planters, etc.): 3 feet
4. Spas and hot tubs: 5 feet
5. Remote AC condensing units: 5 feet
6. Permanent taller structures (trellises, gazebos, sheds, arbors, play structures etc.): 5 feet (to allow adequate clearance from existing one-story eaves and for scaffolding used in two- story siding replacements).
7. Trees: 3 to 5 feet on a case-by-case basis depending on species.

“Clearance” shall be measured from the vertical surface of the structure under consideration (e.g., shed wall, post, lattice face, etc.), or from any horizontal projection (arbor wood cross members, eave fascia, etc.) whichever is *closest* to the wall. Consideration will be given to structures (such as two-post trellises), that can be partially disassembled to allow contractor access on a case-by-case basis. Refer to sections entitled “Barbeques, Grills & Outdoor Kitchens” and “Fire Pits & Outdoor Gas & Wood-burning Appliances” in PART 3, for clearances of heat-producing appliances not contained herein.

Clothes Drying Facilities:

Outdoor clotheslines and clothes drying structures are discouraged, but may be allowed on a case-by-case basis. The BIP CC&R’s provide that clothes drying facilities shall be “adequately

concealed so as not to be visible from another Lot or Common Area”. Clothes drying structures shall be screened with landscaping or other approved method. Clotheslines shall not be attached to private or Community fences, trees, or to an adjacent zero-lot-line wall.

Permanent fixed clothes drying structures (e.g., pole with “T” assembly) and retractable umbrella-style clothes dryers shall require an architectural application and approval. The application shall include a site plan drawing and photos indicating the proposed location of the clothes drying structure(s), and method of screening from public view and adjacent neighbors. Include manufacturer’s literature indicating materials, finishes and height of the clothes drying apparatus. Maximum height shall be 90 inches. Where retractable and removable umbrella-style clothes dryers are used, they shall be removed and stored out of view when not in use.

Decks at Grade:

Ground level decks shall be constructed of pressure-treated framing lumber (substructure), and with decay-resistant lumber such as Con-heart Redwood, Western Red Cedar, and Ipe (Brazilian walnut) for decking, fascia, railings and other exposed wood. Composite wood deck materials (as manufactured by TimberTech/Azek, Trex, and Fiberon, for example), may be used as alternate decking and fascia material in wood tones of medium to dark brown and brown/gray. Wood shall be left in its natural state, sealed with a clear non-gloss sealer, or stained in medium to dark brown and brown/gray wood tones (e.g., standard products lines of Behr, Cabot, Olympic, etc., exterior stain/sealers). Applications shall include the proposed decking/fascia color. Ground level decks shall be a maximum of 12 inches above grade, and no higher than the finish floor elevation of the existing dwelling, whichever is lower. Decks shall be no closer than 6 inches to a fence. Refer to section entitled “Clearance Requirements” in PART 3, for deck setbacks from zero-lot-line walls. Some sloping lots (rear yards), may require special case consideration and should be detailed in any related architectural applications.

Decks at Lagoon Lots:

Elevated decks at lagoon lots may be newly constructed and/or repaired with similar materials and finishes as described in section entitled “Decks at Grade” in PART 3. For deck setbacks, rear yard coverage, and other requirements refer to section entitled “Hardscape at Lagoon Lots” in PART 4. Maximum elevations (heights) of top-of-deck surfaces shall not exceed the floor elevation of the existing dwelling, and shall not be greater than 4 feet above the top of the lagoon curb when cantilevered beyond the curb. Refer to similar sections of the Community Architectural Rules for requirements not contained herein. Where practical the area beneath the deck (lagoon side) shall be landscaped with shade tolerant landscaping (e.g., ground cover, or similar), or screened with Redwood lattice to enhance the appearance. All under-deck areas shall be accessible for maintenance. Architectural applications shall include the following:

1. Drawings (drawn to scale) including site plan with deck location and setbacks; deck plan view with dimensions; side elevations; and details including railings and materials.
2. Color samples.
3. Landscape plan with hardscape and landscape calculations.
4. Photos of the *existing* deck, railings and substructure (consider photos from across the lagoon and/or Google Earth aerial views).

Docks:

Refer to the Community Architectural Rules for information, guidelines, and standard dock drawings not contained herein. Exposed surfaces including decking and perimeter trim (fascia) shall be Con-heart Redwood, Ipe (Brazilian walnut), or Western Red Cedar and shall be left in their natural state, sealed with a clear non-gloss sealer, or finished to match adjacent decks. Refer to section entitled “Decks at Grade” in PART 3, for finishes. Composite wood decking is

permitted as an alternate material for the *decking* only, with the fascia board around the dock remaining Con-heart Redwood or Western Red Cedar. Pressure-treated wood is not permitted on exposed surfaces. Private docks must be maintained in good condition meeting the standards of the Community. Light installations on docks are prohibited. Dock use shall be limited to the launching and enjoyment of up to two (2) small non-motorized boats. Barbecues, garbage containers, sports and other recreational equipment, plants, furniture and other objects on private docks are prohibited.

Fences, Wrought Iron:

The wrought iron fences along the lagoon paths and on lagoon lots are to be painted with suitable primers and finish coat(s) of *Pittsburgh Paints Pitt-Tech DTM 90-444 Satin Bronze Tone*, or equivalent. Replacement fences shall be of similar design as the original fencing, and may be fabricated from wrought iron (steel), or other suitable metals. The iron handrail at the entry of some home models shall be painted to match the original coating color, or other wrought iron fences. Lagoon view lots which have wooden fences may, on a case-by-case basis, replace the wood fences with wrought iron fences not to exceed 42 inches from grade, and must be painted with the same *Pittsburgh Paints Pitt-Tech DTM 90-444 Satin Bronze Tone*, or equivalent. Should any replacement iron fence come with a high-quality black factory finish this will be an acceptable alternative to the satin bronze tone so long as the entire iron fencing matches in style and color.

Fences & Gates, Wood:

Fences and gates shall be constructed of either rough construction-heart (Con-heart) Redwood or Western Red Cedar. Fence posts may be the same material as the fence, or brown-tone pressure-treated wood. Fences and gates shall not be painted or stained, but must be allowed to weather naturally or be sealed with a clear non-gloss sealer. Fences and gates must match the original installation as to materials, style, design, location and size except as noted herein. Gates may be modified from the original developer-installed design, and will be considered on a case-by-case basis. Gates may not contain glass, plastic or metal panels or components. New fences shall *not* be attached to a neighbor's zero-lot-line wall to eliminate vibrations from gates and sound transmission between fence-connected walls, regardless of whether existing fences are currently attached to these walls. A one-half inch (1/2") gap is recommended between fences and zero-lot-line walls. Refer to Exhibit "G-1" – Fence Detail at Zero-Lot-Line Walls, for additional requirements.

Vertical 1 x 8 fence boards may be lapped to match the original developer fences, or have a board-on-board configuration. Bottom kick boards retaining soil shall be 2x pressure-treated brown-tone lumber. Fence posts shall have both a 2 x 4 top rail and a 2 x 6 cap trim. Refer to Exhibit "G" – Standard Fences & Gates, for standard fences between neighboring properties and side yards adjacent to public sidewalks. Similar fence details shall apply to existing short fences (approximately 42" high) between Bay Isle Pointe parks and adjacent residences.

Fence Extensions:

Replacement fences for originally installed Bay Isle Pointe fence *extensions* (not Community fences), shall comply with Exhibit "H" – Fences with Lattice Extensions. Fence extensions shall be constructed of either rough Con-heart Redwood or Western Red Cedar. Fence posts may be the same materials as the fence, or brown-tone pressure-treated wood. Fence extensions in new locations will be considered on a case-by-case basis taking into consideration grade changes between lots, neighbor privacy issues and visual impacts from adjacent streets. Fences and approved extensions may not be painted or stained, but must be allowed to weather naturally or be sealed with a clear non-gloss sealer. Fences with extensions shall not exceed 8 feet in height measured from the lowest adjacent grade.

Extensions to Community-maintained perimeter fences must comply with the CHBI standard details and requirements. Community fences and extensions shall be allowed to weather

naturally and must not be sealed or stained. Fence extensions are not allowed on top of, or attached to, existing pre-cast concrete Community fences along Island Drive. In these locations free-standing arbors incorporating lattice or open slat screening will be considered on a case- by-case basis. Refer to similar sections of the Community Architectural Rules for requirements not contained herein.

Fire Pits & Outdoor Gas & Wood-burning Appliances:

Wood-burning, *open flame* fire pits and barbeques are prohibited because of fire safety issues due to the relatively small yards and close proximity of houses at Bay Isle Pointe. Other self- contained, outdoor *wood-burning* appliances like “chimneys”, free-standing patio fireplaces, and similar appliances (even with spark arresters and/or semi-enclosed combustion chambers with screens or doors), are categorically prohibited. All *wood-burning* fire pits and free-standing appliances have the potential to eject sparks, embers or flames that could ignite surrounding structures, landscaping, and outdoor furniture.

Permanent fire pits and outdoor fireplaces fueled by *propane* or *natural gas* are allowed, and must be installed in accordance with the appliance manufacturer’s printed *installation and operation instructions* including all safety information, warnings, and precautions regarding proximity to combustible structures, landscaping, and furniture. Permanent fire pit and fireplace installations shall comply with all local codes and ordinances, and may require a City of Alameda building permit for *natural gas* equipment. Refer to section entitled “Utilities”, subsection entitled “Gas Line Outdoor Extensions” in PART 2.

All such *permanent* installations shall require an architectural application for approval. The application shall include a site plan drawing indicating the fire pit or fireplace location with dimensions to existing structures and fences, and product literature from the manufacturer. Minimum setbacks for outdoor fireplaces with *enclosed* combustion areas are 5 feet from zero- lot-line walls, and 3 feet from fences. For permanent (fixed-location) *open-flame* fire pits the minimum setbacks are 10 feet from zero-lot-line walls, and 5 feet from fences, or per the gas appliance manufacturer’s recommendation, whichever is *greater*. Permanent outdoor fire pits and fireplaces will be considered on a case-by-case basis depending on size and location.

Firewood:

Firewood storage is permitted in rear and side yards (behind the side fence separating the front and side yards out of public view), and shall be stacked in a neat and orderly manner. Firewood shall not come in contact with fences, houses, or other structures, and shall be kept out of neighbors’ views as much as possible. Minimum clearance to fences shall be 6 inches, and 18 inches from zero-lot-line walls to allow for adequate air circulation.

Flags & Flagpoles:

The American flag and other flags may be wall mounted on a dwelling and displayed publicly. Flags should be maintained in good condition free of tears, stains and other damage. Vertical flag pole installations may be permitted on a case-by-case basis, and require an architectural application that indicates the flag pole location, height, and manufacturer’s product cut sheet.

Garbage, Recycling & Green Waste Bins:

Refuse/recycling bins may be left at the street curb only on the evening prior to, and on the day of scheduled pickup. At all other times, containers must be stored out of sight either inside the garage or in the rear side yard (behind side fence). Garbage containers must be covered at all times to avoid odors and loose trash, and to discourage wildlife (crows/raccoons) from scavenging for food. It is advised that oil-soaked rags not be thrown into trash bins without fumes being neutralized. Fires have been caused by spontaneous combustion of oil-soaked

rags stored in and around trash bins next to dwellings.

Gazebos & Pavilions:

Gazebos and pavilions are freestanding, hip-roofed structures usually square or octagonal in plan with open sides. Gazebos and pavilions shall be constructed of appropriate outdoor wood such as Con-heart Redwood, Western Red Cedar and Ipe, which shall be left in its natural state or sealed with a clear non-gloss sealer. Other earth-tone stain/sealer products may be considered on a case-by-case basis for free-standing structures. Gazebos and pavilions in close proximity to the main dwelling may be painted a color matching the house siding or trim color to be determined on a case-by-case basis. Roofing material shall be cedar shingles/shakes or composition single roofing to closely match the roof of the main dwelling. Canvas, metal, fiberglass or plastic roof coverings are not permitted. The gazebo/pavilion floor elevation shall not exceed 12 inches above grade, or no higher than the finish floor elevation of the main dwelling, whichever is lower. Structures must be set back from the fence a minimum of 3 feet, depending on the proximity of neighboring houses. Refer to section entitled "Clearance Requirements" in PART 3, for setbacks from zero-lot-line walls. Gazebo/pavilion heights over the acceptable standard of 8 feet 6 inches above grade shall be determined on a case-by-case basis.

Generators, Standby Residential:

Residential standby generators are *not* allowed because of lack of suitable yard locations around the closely spaced houses found at Bay Isle Pointe. Standby generators must be in close proximity to existing gas/electric meters, locations that would either impact adjacent neighbors (noise and visibility), or such that requisite equipment setbacks and clearances could not be met in narrow existing side yards.

Insect Traps (Electronic):

Insect traps shall be located as to not create a nuisance to neighboring properties.

Lights (Affixed to Yard Structures):

Light fixtures attached to yard structures are permitted only if they are shielded and do not intrude into neighboring property. Bright emergency type flood lights are not permitted unless they are shielded from public view. Colored light bulbs are prohibited except during the Holiday Season as specified in section entitled "Lights (Attached to House)" in PART 2. Light fixture installations on docks are prohibited.

Mailboxes:

Original mailboxes (rural type with round top) shall be replaced with lockable mailboxes as manufactured by Pinnacle, and fabricated from aluminum plate with a black powder-coated finish. Standard size is 11"W x 11"H x 23"D, Part # 1022 for standard duty, and Part # 1025 for heavy duty using thicker aluminum plate. Visible brackets may not be used to attach the mailbox to the mailbox post. Newspaper tubes are not permitted. Mailboxes shall be maintained to keep the original appearance without dents, broken mailbox doors, or excessive fading of the paint finish. House address numbers shall be neatly attached to the front of mailboxes using self-adhesive vinyl numbers approximately 2 inches in height. Refer to Exhibit "J" – Mailbox Post Detail & Approved Mailbox, for the mailbox manufacturer's contact information.

Mailbox Posts:

Mailbox posts shall match the original installation as to location, materials, size and design. If the concrete footing requires replacement, the old concrete footing shall be removed to allow for the new footing in the same location, unless the mailbox is on private property. The 4 x 6 support post may be set directly in concrete, or may be connected to a Simpson Strong Tie post bracket Model #CBSQ46, or equivalent, fully encased in a concrete footing. Mailbox posts shall

be constructed and installed pursuant to Exhibit "J" - Mailbox Post Detail & Approved Mailbox. The 4 x 6 post material only may be either rough Con-heart Redwood or brown-tone pressure-treated wood with the other wood remaining rough Con-heart Redwood.

Patio Furniture:

Outdoor furniture used in conjunction with landscape and hardscape areas of a residence shall be designed specifically for exterior gardens and patios. The color and style of these exterior furnishings shall harmonize to coordinate with the appearance and finish of the residence.

Radiant Heaters:

Outdoor, free-standing patio radiant heaters, usually portable with a concealed propane tank at the base, vertical support, and heat deflector at the top, shall be stored out of view from neighboring properties and public areas when not in use. Pole-mounted *electric* infrared heaters are discouraged because of their inherent instability (top heavy) and appearance. Maximum height shall not exceed 90 inches. Surface-mounted electric infrared patio heaters (or similar propane heaters), shall be concealed within the framing of arbors or similar yard structures to minimize visual impact to adjacent neighbors and public areas. Surface-mounted heaters shall not be installed on any fences or adjacent zero-lot-line walls, but may be attached to the main dwelling (on walls or under overhangs), and will be considered on a case-by-case basis. All architectural applications shall include photos of proposed surface-mounted heater locations, and product cut sheets.

Sheds:

Larger sheds may be free-standing or attached to the house, and constructed of materials (siding and trim), and colors matching those of the house. Shed roof material and eave details shall match those of the house. For smaller, visually concealed sheds, exposed wood siding (Redwood or Western Red Cedar), may be left natural with a clear sealer, stained in an earth-tone, or painted to match the house. Redwood-colored paint or stain is prohibited. Sheds that consist of pre-finished walls, windows, doors, and roofs constructed of sheet metal, fiberglass, or plastic materials are prohibited. However, smaller pre-fabricated polypropylene sheds in earth-tone colors may, on a case-by-case basis, be allowed based on size, height, location, and visibility from neighboring properties. Sheds may not be higher than the fence, except on a case-by-case basis, for example, when a shed roof and slope matching that of the house, creates a more compatible appearance and does not interfere with a neighbor's view. Sheds must be set back from the fence at least 6 inches including all overhangs (eaves). Refer to section entitled "Clearance Requirements", PART 3, for setbacks from zero-lot-line walls.

Spas & Hot Tubs:

Spas and hot tubs refer to above-ground, portable self-contained units with all operating equipment within the spa/tub cabinet, and often with simulated wood sides and matching cover. Colors for spas, hot tubs and spa/tub covers shall be medium to dark earth tones (browns and grays) to better blend in with the landscaping. Highly reflective spa covers (e.g., off-whites and other light colors) are not allowed. Spa setbacks from existing fences shall be determined on a case-by-case basis depending on the proximity of neighboring houses, but shall not be less than 6 inches. Refer to section entitled "Clearance Requirements" in PART 3, for spa setbacks from zero-lot-line walls.

Spa *operating* sound levels shall not unduly intrude into neighboring properties. Elevated decks around above-ground spas and hot tubs are not allowed. Portable, *inflatable* spas are not allowed. Spas shall be equipped to drain using a garden hose, portable sump pump, or other method. All spa and hot tub water shall only be discharged into the *sanitary* sewer system (e.g., plumbing fixture floor drain, exterior sewer cleanout, etc.). In *no* case shall spa water be

discharged into the garden (yard), or storm drain system (e.g., area drain inlets, downspout inlets, street gutter, or similar storm drain structures), to prevent contamination of the Community lagoons. All spa and hot tub applications shall indicate *how* and *where* the spa/tub unit will be drained.

Speaker systems:

Amplified outdoor speaker system installations are not permitted.

Trellises:

Plant trellises shall not be attached to the house, may not be higher than the top of the fence (or fence extension), nor attached thereto, and must be a minimum of six inches from the fence. Trellises shall be constructed of natural Redwood or Western Red Cedar, which may be treated with a clear non-gloss sealer. Vines or other plants may not be attached to shared fences. For purposes of distinction herein the definition for trellis is a flat framework of open latticework used as a screen or as a support for plants.

Weather Vanes:

Weather vanes and their locations will be considered on a case-by-case basis.

Wind Chimes:

Wind chimes are discouraged, but are permitted only if the sound level does not intrude into neighboring properties.

PART 4 - LANDSCAPE & HARDSCAPE IMPROVEMENTS

Approval Requirements:

No landscaping may be installed, nor any existing landscaping be modified, without the prior approval of the Community Architectural Committee (CAC). An architectural application and drawings must be submitted and approved *prior* to commencing landscape installations. Owners should also review the Community Architectural Rules, SECTION 3 "PLANT GUIDELINES" for drought-tolerant landscaping, plant lists, prohibited plants, and other landscaping information and requirements not contained herein.

Bark & Mulch:

Bark/mulch is a protective covering of organic material laid over the soil around plants to prevent erosion, retain moisture, and sometimes enrich the soil. Mulching shall be of organic (untreated), natural material, such as tree bark, chipped tree components and pre-decomposed plant material. Redwood bark, shredded Redwood bark (*gorilla hair*) or chipped medium fir bark (uncolored) are compatible with the earth tones desired in the landscaping. Artificially colored bark/mulch made from recycled wood chips must use non-toxic, non-leaching dyes. Approved colors for artificially-colored mulch include brown and black. Other colors including red-dyed mulch, and yellow/beige "playground fiber" (chipped light-colored wood) is not allowed.

Composting:

All homeowner-constructed outdoor compost piles/bins and commercially available compost bins and tumblers are *prohibited* because of their attraction to rodents and the potential for annoying and undesirable odors to neighboring properties.

Drainage:

Existing downspout drain lines originally installed by the developer and surface drainage in landscaped areas must be appropriately maintained to avoid impacting on neighboring properties, including common areas. Landscape and hardscape installations shall provide for positive surface runoff toward the street or drainage structure (catch basin), such that water is not allowed to pool against a neighbor's foundation. It is particularly advisable that homeowners check drainage on adjacent property where a Zero Lot Line (ZLL) maintenance easement exists. Ensure that soil is not in contact with existing siding, and that water drains away from the house. As the drainage system is frequently shared by homeowners, it is vital that homeowners communicate to solve drainage issues. Pooling water on property is not allowed to cause drainage issues or property damage to neighbor properties. Pooled water may be regarded as a violation of the CC&R's and/or the architectural standards. Penalties for non-compliance are as specified by the CC&R's.

Drought Tolerant Landscaping:

Refer to Community Architectural Rules, Standards & Plant Guidelines.

Driveways:

Replacement may be like for like using exposed-aggregate concrete (also called washed- aggregate concrete), or interlocking concrete pavers. Where exposed-aggregate concrete is used, ensure that the concrete contractor complies with all local and state environmental laws regarding the concrete "wash" runoff, and that appropriate measures are taken to prevent wash runoff from flowing into street gutters and storm drains which flow into the lagoons. The architectural application shall include a description of the Contractor's proposed methods and procedures to collect and dispose of the concrete wash runoff and sediment per environmental regulations. Smooth or broom-finish concrete is prohibited.

Concrete pavers shall be square and/or rectangular in shape (90-degree angled corners), and set on a crushed rock base with an approved metal restraint system or with the edge pavers set in concrete. The approved colors shall be solid or blended earth tones of gray, charcoal gray, gray

green and browns. Colored applied coatings or painting of driveways is prohibited. Excessive oil stains on existing driveways must be removed.

Hardscape:

Hardscape shall consist of patios, decks, rocks, pavers, brick (or similar) planter borders, areas covered by structures such as gazebos, decomposed granite pathways, synthetic turf, and other *non-landscape* materials. Hardscape areas shall be limited to a portion of the total front or rear yard area. Not more than 40% of the front yard area, and not more than 80% of the rear yard area shall be hardscape material as per the Community Architectural Rules (requires 60% minimum front yard landscaping, and 20% minimum rear yard landscaping). Driveways are excluded in the front yard area calculations. Existing side yard fences perpendicular to the dwelling shall be considered the boundary separating front and rear yards.

Hardscape at Lagoon Lots:

Lagoon lots shall comply with the minimum 20% rear yard landscaping requirement and with Exhibit “K” – Deck & Patio Setbacks for Lagoon Lots, attached hereto. This exhibit establishes minimum setbacks for decks and patios from existing side yard fences and from the lagoon curb for planting areas. These landscape areas provide *buffer zones* between adjacent lots to minimize the appearance of “hardscape run-on”, where a series of decks on adjoining lots abut one another in a continuous, uninterrupted line of decks and railings without landscaping breaks. This setback or envelope requirement shall not apply to any Lagoon Lot rear yard in which the deck was originally approved prior to December 4, 1989, and meeting the 20% landscape requirements.

Existing decks, patio surfaces, and retaining walls may be replaced “in kind” providing the rear yard is in compliance with the 20% minimum landscape requirement, and was originally approved prior to December 4, 1989. Where decks were constructed or modified *without* approval after 1989, or where an entire deck including substructure and framing is being replaced due to dry rot and disrepair, the Exhibit “K” building envelope requirements shall apply. Similarly, all new deck installations or redesign (reconfiguration) of existing decks, patio surfaces, and retaining walls must meet the requirements contained in Exhibit “K”. Replacement decks shall utilize currently approved materials and finishes. Refer to section entitled “Decks at Lagoon Lots” in PART 3, for materials and finishes, maximum deck heights, and other requirements.

Lighting (Low-voltage Accent):

Landscape lighting for accenting rear yard landscape installations is permitted if they are shielded, low-voltage (12V), and have a low, non-glare light level. Only clear glass, non-colored lights, are permitted. Accent lights must not intrude into neighboring property. Limited front yard, low level, low voltage lights are permitted, but must be compatible with the overall neighborhood appearance. Mercury vapor, fluorescent, or quartz lights are prohibited. Light installations on docks are not permitted.

Maintenance:

Owners shall maintain their landscape in good condition, removing weeds, watering, fertilizing and trimming as necessary to maintain an attractive appearance. Lawns shall not exceed more than 5 inches in height, and shall be edged at the sidewalk, driveway and/or curb so as not to grow over these areas.

Trees and shrubs shall be pruned to provide ample clearance from a neighbor’s zero-lot-line wall to eliminate any rubbing or scratching against the wall during windy conditions, and to minimize limb encroachment over adjacent neighboring properties. Tree root systems should be monitored to minimize intrusion into neighboring yards that may cause damage to fences and uplifting of lawns, patios and driveways. Refer to section entitled “Drainage” in PART 4, for drainage maintenance and earth-wood separation at neighboring zero-lot-line walls.

Patios:

Patio size shall be in reasonable proportion to the landscaped yard area. Acceptable patio materials include exposed-aggregate concrete, stamped concrete in an acceptable pattern and earth-tone color, broom-finish concrete in an earth-tone color, brick, concrete pavers, flagstone, slate, or other acceptable stone materials. Applications will be reviewed on a case-by-case basis. Applied paint or colored coatings are prohibited except for a clear sealer. For purposes of distinction herein the definition of a patio is a hard-surfaced paved recreation area on grade that adjoins a dwelling, and located in a side or rear yard. Refer to section entitled "Clearance Requirements" in PART 3, for minimum patio setbacks from zero-lot-line walls.

Planter Boxes & Flower Containers:

Above-grade planter boxes and flower containers visible in front yards shall be compatible with the house and overall neighborhood design.

Rock Gardens:

Rock gardens in front yards are discouraged, but will be considered on a case-by-case basis if they contain an acceptable balance of rock and live plant material, and are compatible with the overall neighborhood design. Rock is to be earth tone in color. Bright white rock and red lava rock are prohibited. Rock gardens are considered "hardscape" (non-landscape), and shall be in compliance with the provisions set forth in the section entitled "Hardscape" in PART 4.

Synthetic Turf:

California Assembly Bill No. 349 (AB 349), passed in 2015 in response to the California drought, prevents homeowner associations (HOA's) from prohibiting the installation of artificial turf to replace lawns. AB 349 allows HOA's to develop and implement reasonable landscape rules and standards regarding type, quality and degree of coverage for artificial turf that resembles grass.

Architectural Applications:

All synthetic (artificial) turf installations shall require architectural applications for approval prior to installation, and will be considered on a case-by-case basis.

Submittals:

The following items are required to be submitted with the architectural application:

1. Plans/Diagrams: Detailed site plan drawn to scale showing synthetic turf, planted areas, and hardscape (driveways excluded), with accurate area calculations of each.
2. Product Cut Sheets & Brochures: Synthetic turf material including country of origin (e.g. USA or China), color, pile height/weight, pile material/fiber shape, tufting gage, thatch, infill, backing material, and related information.
3. Photographs of existing yard, existing trees, and proposed synthetic turf areas.
4. Detail Drawing/Description: Sub-grade preparation description, synthetic turf and edge border/curb detail.
5. Synthetic Turf Sample: Turf sample shall include infill material, and have attached product-identifying specifications from the manufacturer including country of origin; minimum sample size 6" x 6" up to 12" x 12" maximum.
6. Warranty & Contract: Provide warranties from the synthetic turf manufacturer and installation contractor (installer). Include a copy of the installer's proposal (contract) indicating the synthetic turf product name and specification to be used.

Application of Existing Rules/Standards:

Synthetic turf will be considered “hardscape” (non-planted area) when applying minimum landscaped area (e.g., “softscape”) requirements, since it is not living plant material or organic bark/mulch. Generally, the Community Architectural Rules shall apply requiring a minimum of 60% planted area in front yards, and 20% planted area in rear yards. Synthetic turf will not be allowed in front yards unless it replaces pre-existing lawns. When considering artificial turf, no front/rear yard shall contain both living grass lawn and synthetic turf at the completion of the turf replacement project. The following supplemental rules and standards shall apply:

Front yards with existing lawns:

1. Notwithstanding the 60% planted area minimum, for every square foot of existing planted area that is replaced with drought tolerant landscaping with drip irrigation, one (1) square foot of synthetic turf will count as softscape. The same softscape “credit” applies to existing planted areas meeting this requirement.
2. Notwithstanding the 60% planted area minimum, for every square foot of existing hardscape (e.g., rocks, pavers, stepping stones, etc.), that is replaced with drought tolerant landscaping and drip irrigation, two (2) square feet of synthetic turf will count as softscape.
3. When applying the softscape “credits” for synthetic turf as described above no more than 50% of the total softscape area shall be synthetic turf.
4. Where synthetic turf is installed a minimum 2-foot wide landscape buffer shall be required adjacent to house/garage walls, fences, between artificial turf and existing adjacent lawns, and along public sidewalks and concrete street curbs as practicable.

Rear Yards:

Synthetic turf is considered hardscape similar to decks, patios, rocks, etc., with a total maximum of 80% hardscape allowed (20% minimum planted area). Where synthetic turf is installed a minimum 2-foot wide landscape buffer is required adjacent to house/garage walls and fences. Where rear yards front on lagoons a minimum 2-foot wide “river rock” or landscape buffer is required between the synthetic turf and lagoon concrete edge.

Contractor Qualifications:

Synthetic turf contractors shall be licensed and current with the Contractors State Licensing Board (CSLB) and have a D-12-Synthetic Products Contractor classification amongst other licenses carried. The turf contractor shall carry appropriate General Liability and Workers Compensation Insurance, and have substantial, multiple project experience with installing synthetic turf. The contractor shall provide a list of at least five (5) completed local synthetic turf projects with addresses of the installations and client contact information for references.

Synthetic Turf Minimum Standards:

Synthetic turf shall be realistic and natural in appearance and color, and must be manufactured with non-toxic materials. The turf shall be comprised of both thatch and grass fibers that have UV protection and good color retention. Grass fibers shall be straight monofilament fiber of three-dimensional yarn types (no flat yarn is allowed) with an integral primary woven backing and secondary backing coating. The backing shall be

porous to allow drainage at a minimum flow rate of 25-inches per hour. Infill material shall be silica sand and other materials formulated for pet or special use (rubber infill is not allowed). All synthetic turf installations shall incorporate weed barriers. For rear yards artificial turf shall be formulated for pet and high traffic use. Synthetic turf shall meet the following physical properties:

Front Yards (low traffic, appearance):

1. Face Weight: 70 oz. minimum
2. Pile Height: 1.75" minimum
3. Tufting Gauge: 3/8" or less
4. Net Backing Weight: 20 oz. minimum

Rear Yards (high traffic, family yard activity, pets, putting greens):

1. Face Weight: 60 oz. minimum (putting greens excluded)
2. Pile Height: 1.25" minimum (putting greens excluded)
3. Tufting Gauge: 3/8" or less
4. Net Backing Weight: 17 oz. minimum

Installation:

Synthetic turf shall be professionally installed per the turf manufacturer's written installation instructions and recommendations, and must meet the following requirements:

1. Synthetic Turf Verification: At the completion of the synthetic turf installation the Homeowner shall have the turf installer sign a statement that the artificial turf products and installation methods used, exactly match the turf products and installation methods described in the owner/installer executed contract, and those submitted and approved by the Community. The Homeowner shall submit the installer's signed statement to the Community office for verification within 30 days and call for a final inspection. The swapping out of the approved turf for a different, cheaper or inferior product shall be prohibited.
2. Base & Drainage: Existing sod and soil must be removed for the installation of 3 to 4 inches of compacted base rock sub-grade under the synthetic turf to allow for proper drainage and support. Care should be taken to avoid damage to existing tree roots.
3. Surface Drainage: Synthetic turf installation must not negatively affect existing surface drainage patterns, and shall be crowned or otherwise sloped to avoid low spots and ponding.
4. Appearance: Synthetic turf surfaces must appear natural and seamless without sags and ripples, and shall be tight to the contour of the sub-grade with adequate infill ballast. Turf edges shall be neatly cut and tight against adjacent borders. Artificial turf borders shall adequately support and contain the turf edge for the life of the synthetic turf. Edging materials may include metal edging, bender board, concrete border, or other materials to protect the synthetic turf from debris and damage.

5. Existing Trees: For synthetic turf installations that replace existing lawns where there are existing established trees, the Homeowner shall ensure that the turf installer take measures to protect the existing trees from damage and to reduce the likelihood of future root damage to the artificial turf. In no case shall an existing front/rear yard tree be removed for a synthetic turf installation without prior Community approval.

Maintenance:

Synthetic turf shall be maintained by the Homeowner per the manufacturer's requirements and recommendations, and in a manner that maintains its installation integrity and appearance. Damage or deterioration such as tears, ragged edges, loose turf, premature fading, or any other wear or quality problem shall be repaired by an authorized synthetic turf installer within thirty (30) days of notification by the Community.

Warranty:

Synthetic turf shall have a manufacturer's warranty of 15 years minimum, and an installation warranty of 10 years minimum. Irrespective of the material warranty, and at the discretion of the Community, the synthetic turf must be replaced upon determination that the turf is in poor condition and at the end of its serviceable life.

Tree Installations:

Tree installations require prior approval of the species and planting location. Fruit-bearing trees are permitted only in back yards. Replacement of problem trees will be considered on a case-by-case basis, provided a replacement tree, or shrub is approved by the Community Architectural Committee. The minimum tree replacement size shall be 15 gallon and with a minimum height of 6 feet, a minimum breadth of 2.5 feet, and minimum caliper of .75 to 1.25 inches. Tree and shrub installations shall not unduly interfere with neighboring property (yards) or views. Trees shall be maintained in a healthy condition. If a tree's disease becomes untreatable, or if it dies, the owner should promptly submit an architectural application for the removal, and/or replacement of the tree. Refer to section entitled "Clearance Requirements" in PART 3, for tree distances from zero-lot-line walls.

Vegetable Gardens:

Vegetable gardens are permitted only in rear yards and in reasonable proportion to other landscaping.

Walkways:

Walkway materials shall be similar to patio materials and may consist of exposed-aggregate concrete, broom-finish concrete, concrete pavers, brick, flagstone, slate or other earth tone materials depending on their location and compatibility with the house and overall landscape design. Crushed compacted earth-tone rock (decomposed granite and similar materials) is allowed for minor landscape pathways only. Front walkways that match the driveway paving material are encouraged. Separate side yard (service) walkways may be broom-finish concrete. Other surfaces may be considered on a case-by-case basis. Painted surfaces or colored coatings are prohibited, except for clear sealers on concrete pavers. Decorative (accent) border materials must be compatible with the existing house and overall neighborhood design.

ABBREVIATIONS & PHRASES

AC – Air conditioning

BIP – Bay Isle Pointe Homeowners' Association

“BIP Architectural Standards” – *BIP Architectural Standards, Rules & Landscape Guidelines*

CAC – Community Architectural Committee

cfm – Cubic feet per minute (measure of air volume exhausted per minute)

CC&R's – Declaration of Covenants, Conditions and Restrictions

CHBI – Community of Harbor Bay Isle Owners' Association

HOA – Homeowners Association (in general)

“Community” – Community of Harbor Bay Isle Owners' Association

“Community Architectural Rules” – *CHBI Architectural Rules, Standards & Plant Guidelines*

PAC – Project Architectural Committee

“Project” – Bay Isle Pointe Homeowners' Association

GLOSSARY OF TERMS (Partial List)

Refer to the Community Architectural Rules, Exhibit "D" – *Glossary of Terms*, for a complete list of general, architectural/building, landscaping, and planting terms not contained herein.

"Building Envelope" – The limits or boundaries of an area within which certain improvements may be constructed for a rear yard fronting on the lagoon.

"Case-By-Case Basis" – The item being proposed for use may be acceptable depending on the situation. For example, a decorative front door design may be approved when the front door is not visible from the street. However, it may not be approved if the entrance is highly visible, and the door design is not compatible with other doors in the neighborhood.

"Clearance Requirements" – In order to maintain properties and structures, and to assure proper drainage on residential lots, the Project Architectural Standards require specific clearances (setbacks) from existing zero-lot-line walls and fences when installing permanent (not easily moved) items. These items may include, but are not limited to, paving materials (e.g., concrete, flagstone, bricks, etc.), decks, docks, trees, spas, arbors, gazebos, sheds, play structures, fixed benches, etc.

"Exposed-aggregate Concrete" (also referred to as "washed-aggregate" concrete) - A decorative finish for concrete work, achieved by removing (washing off) the outer top surface of mortar, generally before the concrete has fully hardened, and exposing the coarser aggregate of the concrete mix for a more aesthetic appearance.

"Hardscape" - Elements added to a natural landscape such as paving stones, gravel/rock, patios, walkways, retaining walls, fountains, and other *non-landscape* features.

"Like for Like", or "In Kind"- The item being replaced/repared will be exactly like the original item in color, material, size, style, design, location, etc., the same as "match existing".

"Match Existing" - The item being replaced/repared will be exactly like the original item in color, material, size, style, design, location, etc., the same as "like for like" or "in kind".

"Per Code" – Any and all State and Federal building codes adopted by the City of Alameda.

"Product Cut Sheet" - A product cut sheet is a general term for a few pages of specifications, instructions, dimensions, etc. that apply to a certain technical product or product line, generally shipped with the product. Often the same as a brochure, or part of a brochure.

"Setback" - Minimum distance that a City zoning ordinance requires that must be maintained between a structure and property lines or between two structures. Also, minimum clearance (distance) between a permanent yard improvement and a zero-lot-line wall or fence.

"Softscape" – Landscaped area on a property including plants, ground cover, and mulch.

"Zero-Lot-Line Wall" – A configuration of properties where the physical wall of one property serves as the boundary for the yard of an adjacent property. Zero-lot-line walls are devoid of windows or other openings, except vents, and involves maintenance easements. Check your Grant Deed for information on your specific property.

AMENDMENTS

1. In PART 2- BUILDING EXTERIOR MODIFICATIONS add the following paragraph to the section entitled "Air Conditioners & Condensing Units". (effective 2022)
"Remote condensing units (e.g. AC compressors, heat pumps, etc., located outside) shall have manufacturer's published "operating" sound rating not to exceed 55 dBA.
2. In PART 2- BUILDING EXTERIOR MODIFICATIONS add the following sentence to the section entitled "Materials", subsection "Cedar Wood Shakes". (effective 2024)
"Please be advised that insurance companies may no longer insure homes with wooden roofs".
3. In PART 2- BUILDING EXTERIOR MODIFICATIONS add the following sentence to the section entitled "Materials", subsection "Fiberglass-Asphalt Composition Shingles". (effective 2024)
"Be advised that the lifetime rating on some products may be lower than the recommended options above."
4. In PART 2- BUILDING EXTERIOR MODIFICATIONS add the following sentences to the section entitled "Solar Energy Systems". (effective 2024)
"...or in the side or rear of the yard behind the fence not visible from a street, path, or lagoon" and "Please note that some manufacturers may integrate an energy storage battery as part of their inverter/solar equipment package and these shall still be considered batteries in terms of their required placement in the home/yard."
5. In PART 2- BUILDING EXTERIOR MODIFICATIONS add the following sentence to the section entitled "Windows & Sliding Patio Doors". (effective 2024)
"With the advent of vinyl, fiberglass, and composite windows there is now a wide range of 'dark bronze' look-alikes with no real industry standard in colors and names of colors. Existing windows now vary in color from medium bronze (brown), dark bronze, very dark bronze to almost black, and now 'black' as an actual color with some window companies. These similar colors will be considered as an 'approved equivalent' to the dark anodized bronze color.
6. In PART 2- BUILDING EXTERIOR MODIFICATIONS remove the following sentence to the section entitled "Windows & Sliding Patio Doors". (effective 2024)
"Windows and sliding doors shall be supplied from one manufacturer."
7. In PART 3- OUTDOOR YARD STRUCTURES & ACCESSORIES add the following sentence to the section titled "Fences, Wrought Iron". (effective 2024)
"Should any replacement iron fence come with a high quality black factory finish paint this will be an acceptable alternative to the satin bronze tone so long as the entire iron fencing matches in style and color."

EXHIBITS

The following Exhibits are attached hereto:

Exhibit "A" – Architectural & Landscape Approval Process

Exhibit "B" – Garage Doors

Exhibit "B-1" – Garage Door Alternate Styles

Exhibit "C" – Gutters & Downspouts

Exhibit "D" – House Painting Detail Guide

Exhibit "E" – Roofing Materials & Rake Detail

Exhibit "F" – Window Replacement Installation Details

Exhibit "G" – Standard Fences & Gates

Exhibit "G-1" – Fence Detail at Zero-Lot-Line Walls

Exhibit "H" – Fences with Lattice Extensions

Exhibit "J" – Mailbox Post Detail & Approved Mailbox

Exhibit "K" – Deck & Patio Setbacks for Lagoon Lots

EXHIBIT "A"

ARCHITECTURAL & LANDSCAPE APPROVAL PROCESS

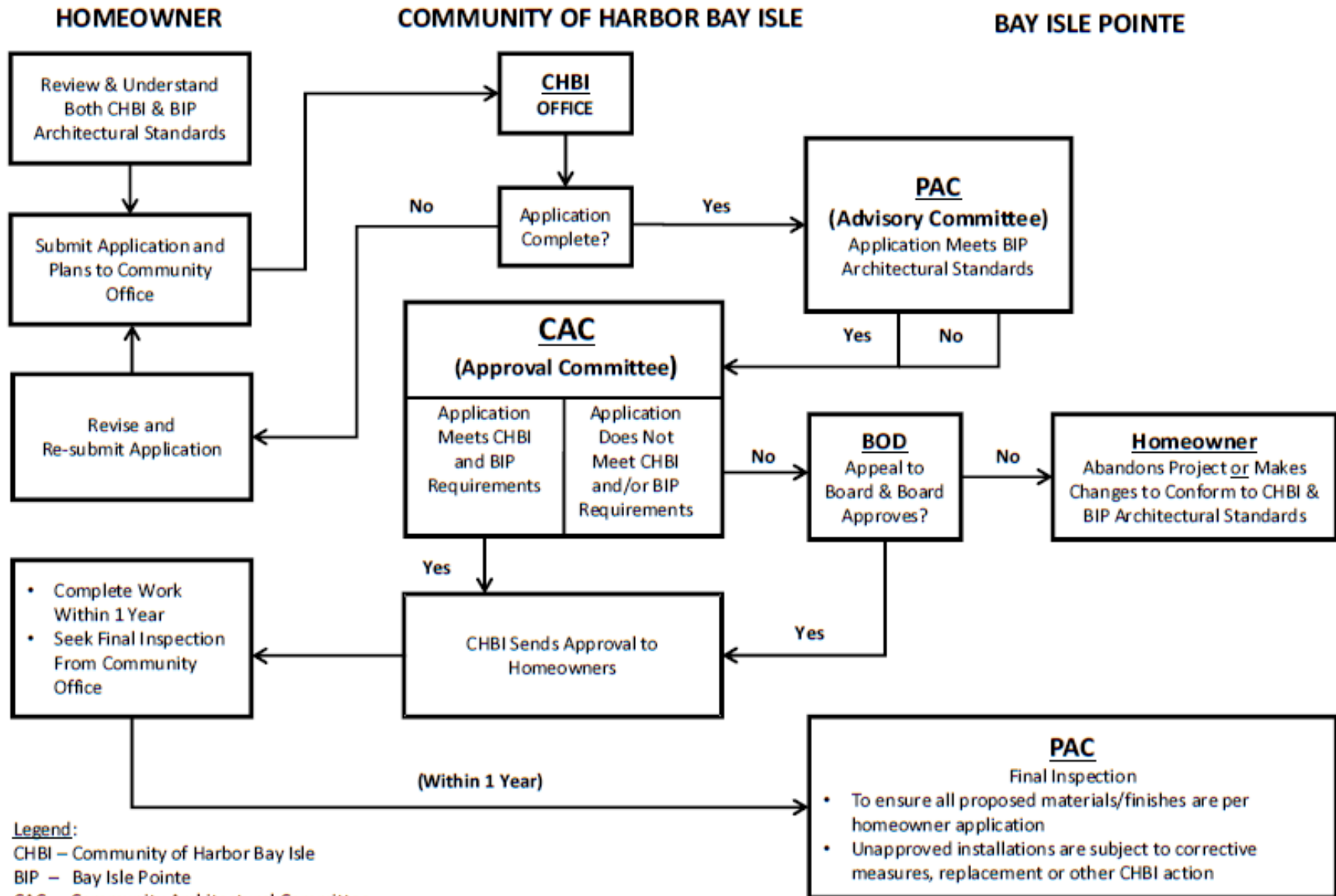

EXHIBIT "B"

Garage Doors

Replacement Doors

Garage replacement doors may be wood or metal sectional overhead doors of the same size as the original door. Standard garage doors are insulated raised-panel metal doors with 16 panels. For other approved garage door styles Refer to Exhibit "B-1" -Garage Door Alternate Styles.

- Metal garage doors shall have a wood-textured finish.
- Doors must be painted with the same paint as the house to exactly match the siding or trim color and sheen. All garage door *factory finish* coatings must be painted.
- Two-color garage doors are not permitted.

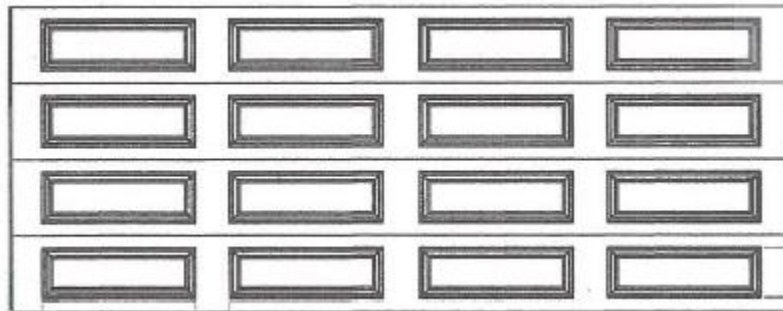

Standard Garage Door

Garage Doors with Windows

Garage doors may have windows subject to the following limitations:

- Windows must be located across the top row of door panels, four panels across.
- Windows shall be one piece of glass without divided panes.
- Glass shall be frosted or obscure glass without color.

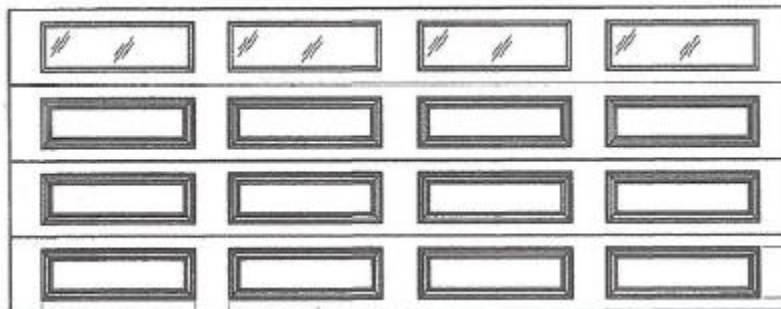

Standard Garage Door with Windows

EXHIBIT "B-1"

Garage Door Alternate Styles

General Requirements

The alternate garage door styles shown are manufactured by Clopay garage doors and are selected from the 'Coachman Collection'. Similar door styles and configurations may be selected from other garage door manufacturers. Decorative black-finish door handles and hinges that mimic "carriage house" styles are not allowed on exterior garage door surfaces.

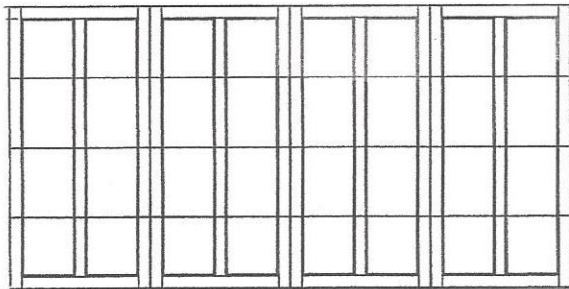

1

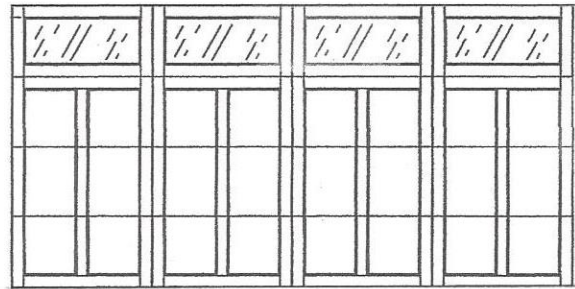

2

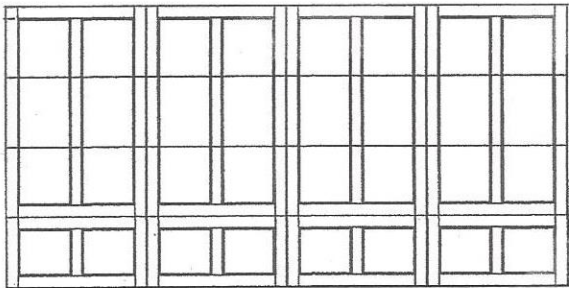

3

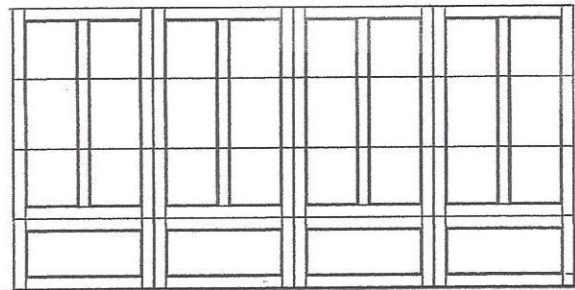

4

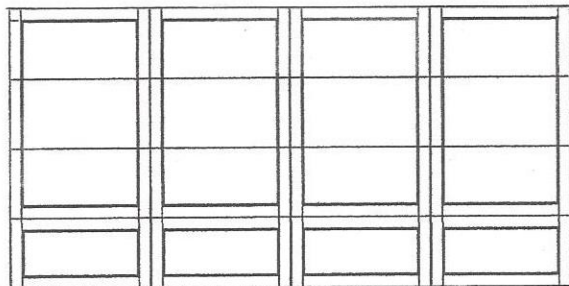

5

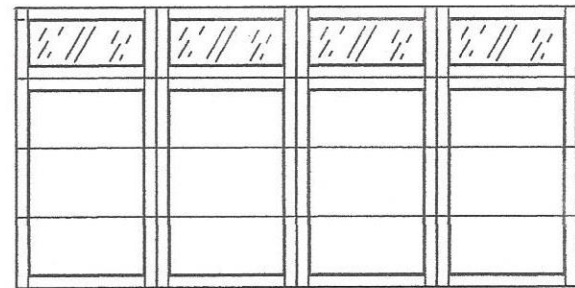

6

EXHIBIT "C"

Gutters & Downspouts

Approved Gutter Profiles-

Replacement gutters and downspouts may be galvanized steel or aluminum, and must be similar in size and shape to the original installation. All gutters on the dwelling must be of the same style, size and material, and all downspouts must match accordingly.

- Gutters shall be standard 5-1/4" deep fascia gutters with either a curved face or straight face with one to three reinforcing ribs.
- Downspouts shall be standard 2" x 3" rectangular shape with flat or ribbed surfaces.

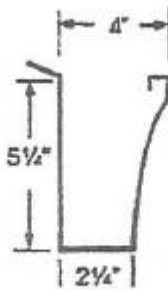
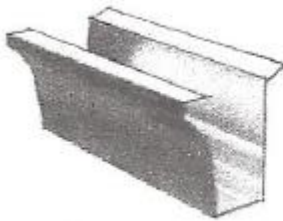

FASCIA GUTTER WITH CURVED FACE

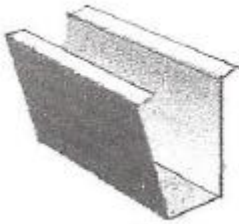

FASCIA GUTTER WITH FLAT, RIBBED FACE

Painting of Gutters

- All replacement gutters, including those with factory-applied coatings, must be painted using the same paint and color as the fascia against which they rest (trim or accent color as approved).
- Where gutters are attached directly to eave rafter tails without a fascia board, the gutter is to be painted the trim color (or accent color as approved), and the rafter tails are to be painted the siding color.

Painting of Downspouts

- All replacement downspouts, including those with factory-applied coatings, must be painted using the same paint and color as the surface against which they rest (trim color. where against trim, siding color where against siding).
- Where downspouts cross over brick masonry, they are to be painted using the same paint and color as the siding.

EXHIBIT "D"

House Painting Detail Guide

Architectural Application:

All exterior house painting shall require an Architectural Application to be filed at the Community office and approved by the Community Architectural Committee (CAC) prior to start of any painting work.

Color Schemes & Palettes:

- No color changes are allowed after a color scheme has been approved unless changes are resubmitted and approved by the CAC.
- Color Palette is based on Kelly Moore colors; other manufacturer's *matched* colors are acceptable.
- Paint colors must be selected from the same *Paint Scheme* in the Paint Palette consisting of *one* siding color and *one* trim color. *One* accent color is optional with no more than three colors total.
- Neighboring houses on either side or directly across the street, may not be painted the same color.

Paint Gloss Categories:

- Siding (Main) Color: Flat, Low Sheen or Eggshell
- Trim and Accent Color: Low Sheen, Eggshell or Satin
- Front Entry & French Doors: Satin or Semi-Gloss
- High Gloss paint is *not* allowed on any surface

Painting of Building Components:

- Front Entry & French Doors: Wood-tone stain with clear finish, or paint to match the siding, trim or accent color. Front entry doors shall be painted *one* color only.
- Garage Doors: Paint *one* color (siding or trim color) using house paint; factory coatings not allowed.
- Exposed Metal: Gutters, downspouts, louvered vents, meters, utility boxes, piping, etc., shall be painted the color of the surface to which they are attached.
- Exposed Roofing Metal: Roof jacks, flues, vent pipes, diverters, etc., shall be painted to match the roofing surface color.
- Cap Flashing at Top of Chimney: Paint to match adjacent trim color.
- Chimney Spark Arrestors & Vents: Paint to match siding, trim, or roof color, whichever is darkest.

Architectural Elements of a House - Painting Guide:

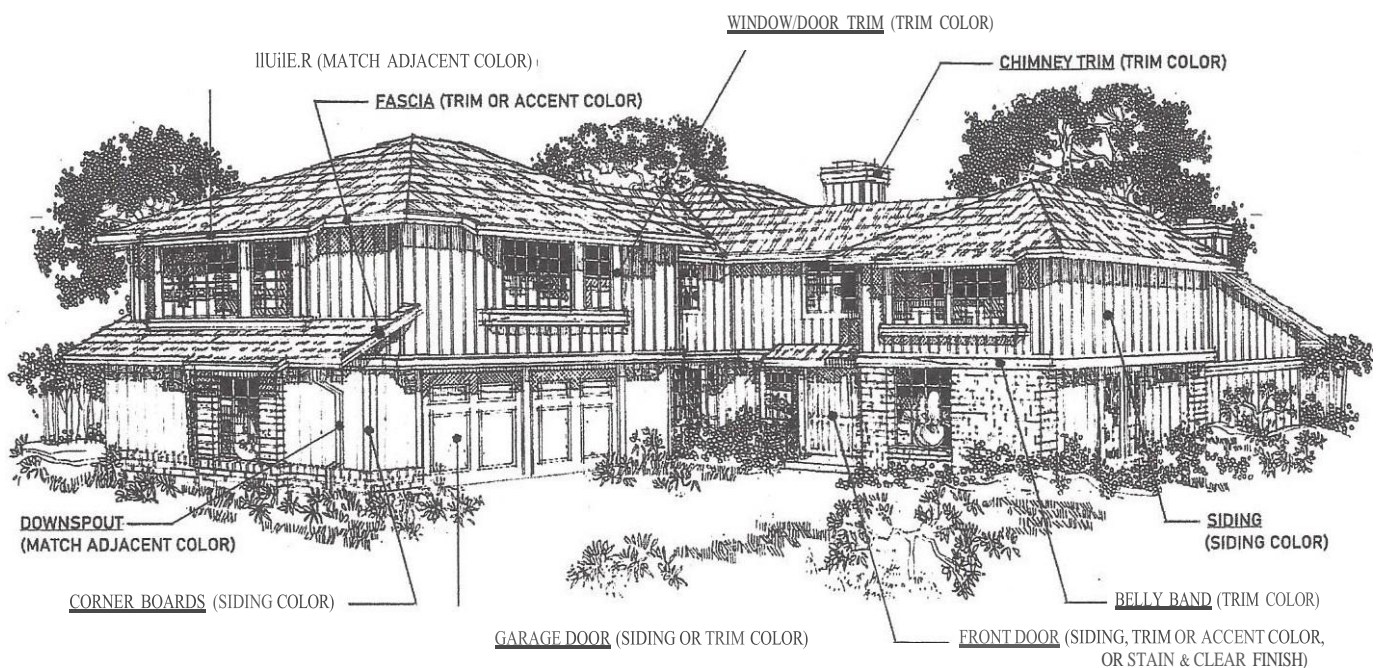

EXHIBIT "E"

Roofing Materials & Rake Detail

Architectural Application & Permit: The property owner must submit an *Architectural Application* to the Community Office *prior* to installing a new roof. The application shall state whether the gutters and downspouts will be replaced with the roofing work. A building permit from the City of Alameda is required for all roofing work.

Approved Roofing Materials:

1. Cedar Wood Shakes: Class A fire-rated roof system comprised of fire-retardant treated cedar shakes, hand split with $\frac{3}{4}$ " minimum thickness, installed over an approved fire-resistant underlayment system, and approved by the City of Alameda. Note that insurance companies may no longer insure homes with wooden roofs.
2. Fiberglass-Asphalt Composition Shingles:
 - CertainTeed Landmark TL triple-layer dimensional shingles, Country Grey color.
 - GAF Timberline Ultra HD (Ultra High Definition), multi-layered roof shingles, Weathered Wood color. Be advised that the lifetime rating on some products may be lower than the recommended options above

Property owners may submit roofing materials other than those listed to be considered by the Project Board of Directors, *prior* to the start of roofing installation. When considering other roofing products that weigh more than the approved roofing, the Owner shall submit a letter from a licensed engineer that the existing roof *structure* will support the weight of the proposed roofing materials. Gable rake roof tiles that wrap the edge of the roof rake and cover part of the fascia, are not allowed (see details below).

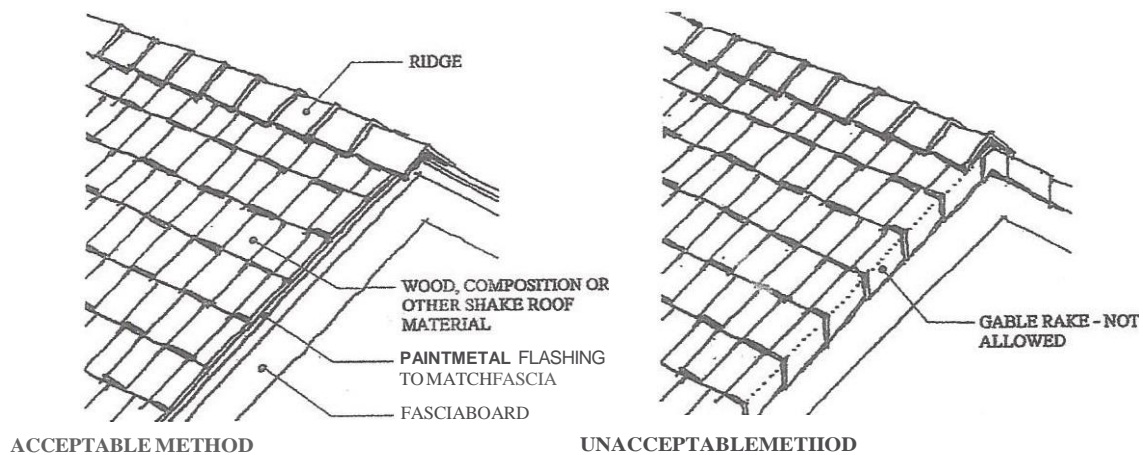

Gutters & Downspouts: Refer to Exhibit "C" - Gutters & Downspouts, for requirements.

Roof Metals: All roof metals (flashings, diverters, vents, pipes, etc.) must be painted to match the roof color. Roof edge flashing (*nosing*) shall be painted to match the adjacent rake or gutter fascia. It is recommended that other roof-related sheet metal work be inspected at the time of re-roofing to include:

- Chimney cap flashing and spark arrestor
- Wood trim "Z" flashing at the top of the chimney

Contractor Signs: Contractor signs are not permitted on private property or on Community Association common areas including curbside landscaped areas.

Final Inspection: A re-roofing final inspection must be requested within 45 days from completion of the roofing work.

Exhibit "F"

Window Replacement Installation Details

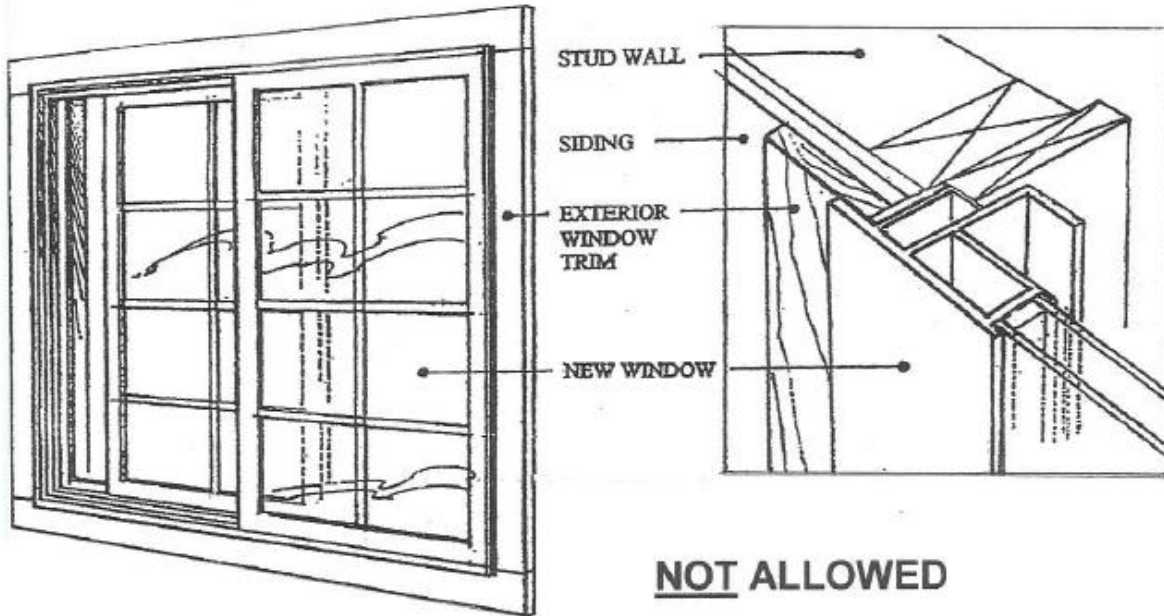

Unacceptable Installation

NOT ALLOWED

Window installs over existing wood trim
Window extends beyond window trim

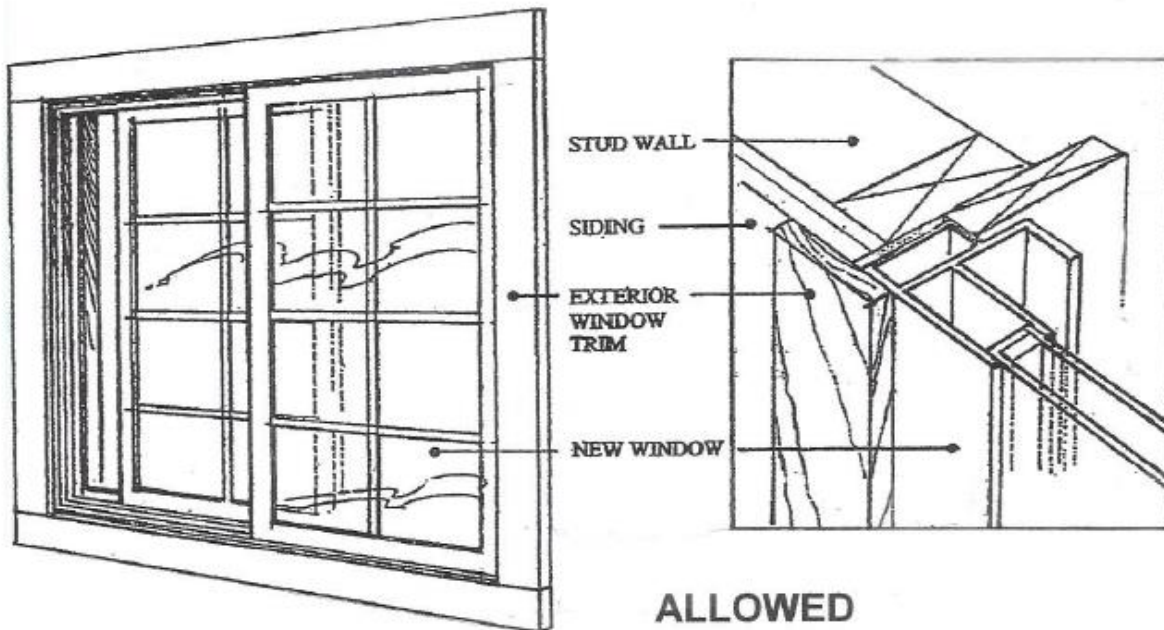

Acceptable Installation

ALLOWED

Window frame recessed from wood trim
Window frame flush with wood trim

EXHIBIT "G"

Standard Fences & Gates

General Requirements

Fences and gates may be constructed of either rough Con-heart Redwood or Western Red Cedar, and must match the original developer fence installation as to materials, design, location and size.

- Fence posts and kick boards retaining soil may be brown-tone pressure-treated lumber.
- Fences and gates shall not be painted or stained, but must be allowed to weather naturally or be sealed with a clear non-gloss sealer.
- Gates may be modified from the original developer-installed design, and will be considered on a case-by-case basis.
- New fences shall *not* be attached to a neighbor's zero-lot-line wall to eliminate vibrations from gates, and sound transmission between fence-connected walls. See Exhibit "G-1" - Fence Detail at Zero-Lot-Line Walls.

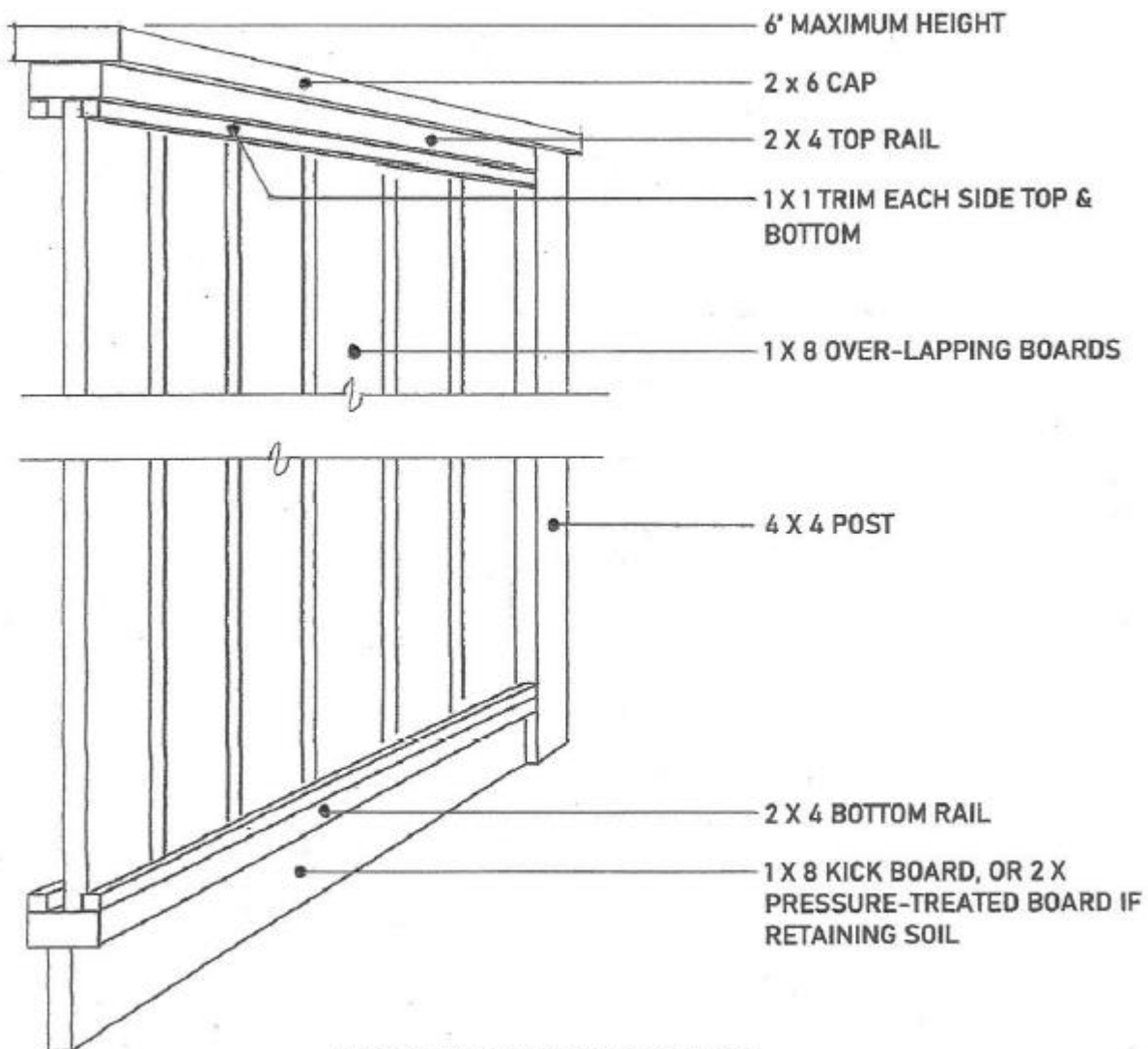

STANDARD FENCE DETAIL

EXHIBIT "G-1"

Fence Detail at Zero-Lot-Line Walls

General Requirements

New fences shall *not* be attached to a neighbor's zero-lot-line wall to eliminate vibrations from gates, and sound transmission between fence-connected walls, regardless of whether existing fences to be replaced are currently attached to these walls. An approximate 1/2" gap shall be provided between the new fence and existing zero-lot-line wall.

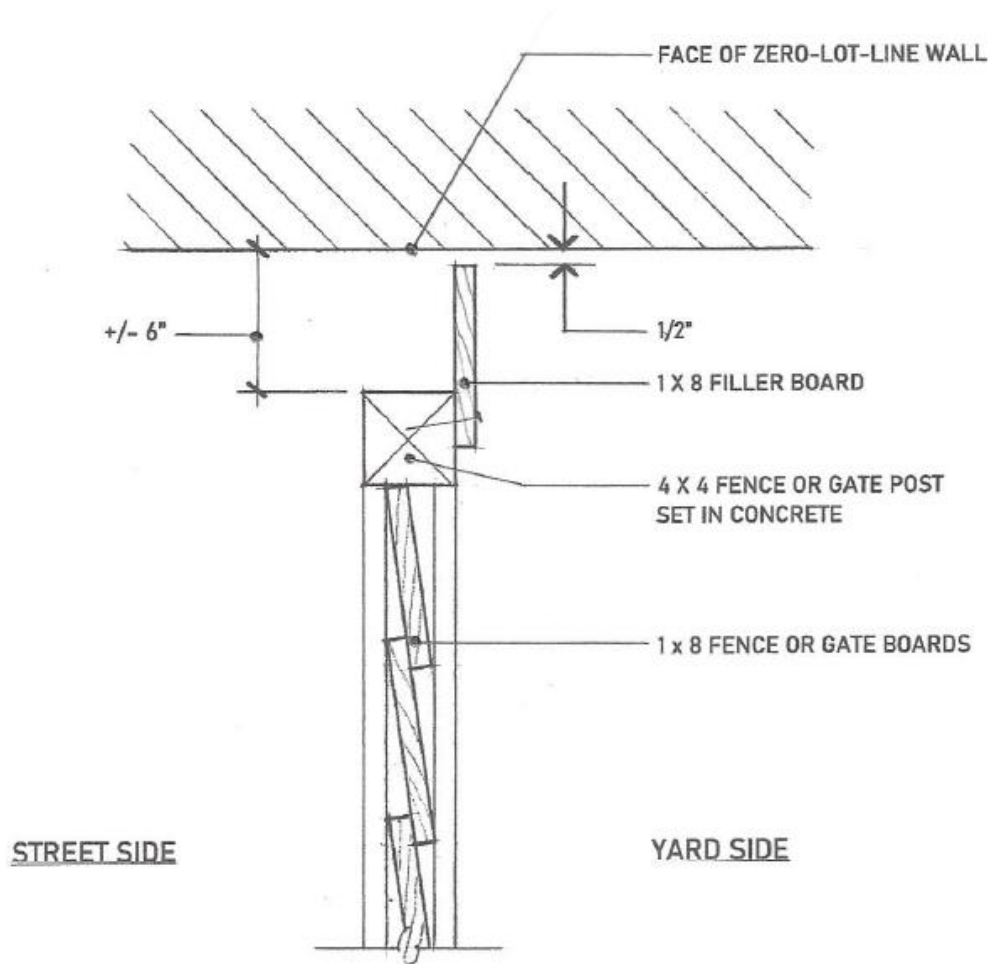

FENCE-TO-WALL DETAIL
(Zero-Lot-Line Walls)

EXHIBIT "H"

Fences with Lattice Extensions

General Requirements

Fences with extensions may be constructed of either rough Con-heart Redwood or Western Red Cedar, and must match the original developer fence installation as to materials, design, location and size. The top of the lattice extension shall not exceed 8 feet above the lowest grade on either side of the fence per City of Alameda requirements.

- Fence extensions must be constructed with a *new* fence, not added to an existing fence.
- Fence posts and kick boards retaining soil may be brown-tone pressure-treated lumber.
- Fences and extensions shall not be painted or stained, but must be allowed to weather naturally or be sealed with a clear non-gloss sealer.
- For lattice fence extensions to Community *perimeter fences* refer to the Community's "Specifications for Lattice Fence Extensions" information sheet.

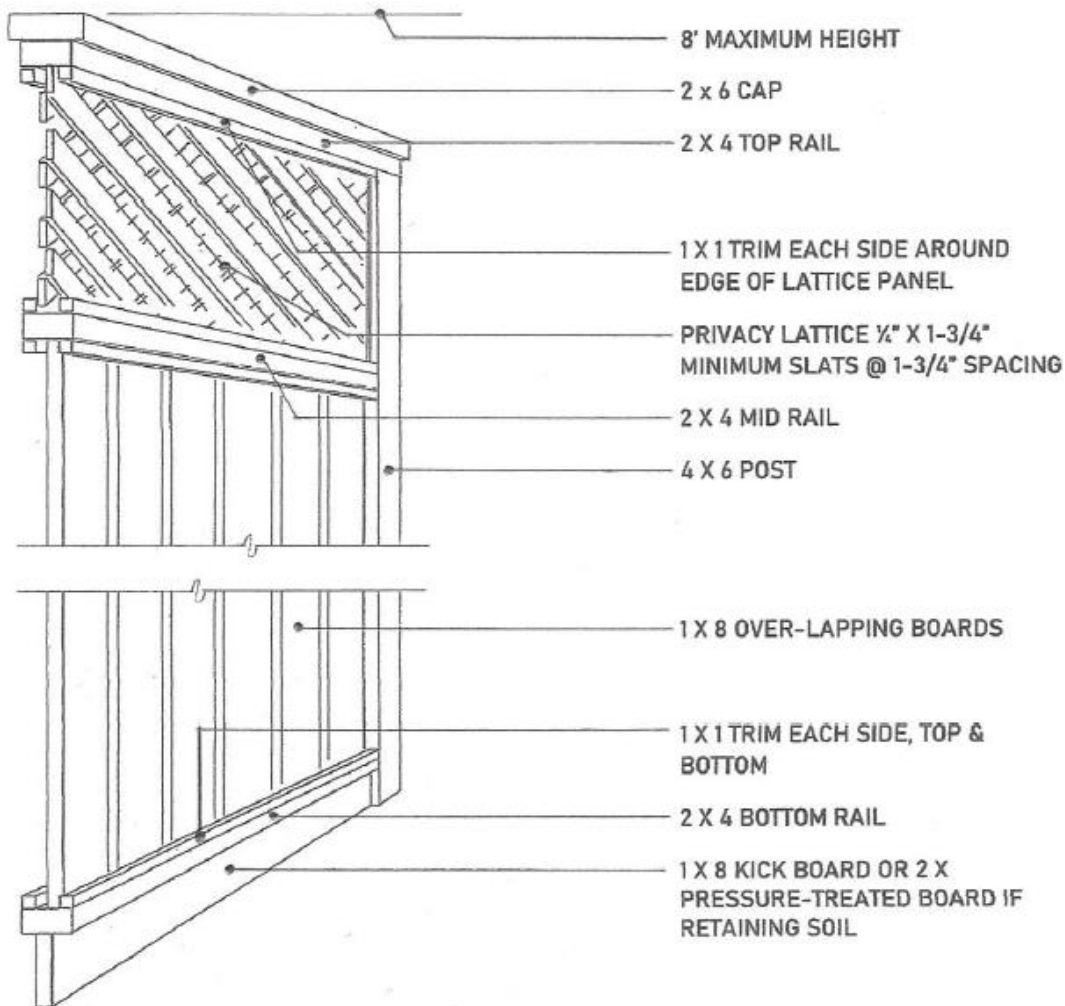

STANDARD FENCE EXTENSION DETAIL

EXHIBIT "J"

Mailbox Post Detail & Approved Mailbox

General Requirements

Mailbox posts must be constructed of rough Con-heart (construction heart) Redwood, except that the main 4 x 6 post *only* may be brown-tone pressure-treated wood. Fasteners shall be hot-dipped galvanized steel.

- The old post footing shall be removed to allow for the new footing in the same location.
- The main support post may be set in concrete, or attached to a metal post bracket fully encased in concrete using a Simpson Strong Tie CBSQ66 bracket, or similar.

Approved Mailbox

Pinnacle Locking Mailbox

www.lockingmailbox.com

Standard, Regular Duty #1022

Standard, Heavy Duty #1025

Size: 11"W x 11"H x 23"D

Color: Black

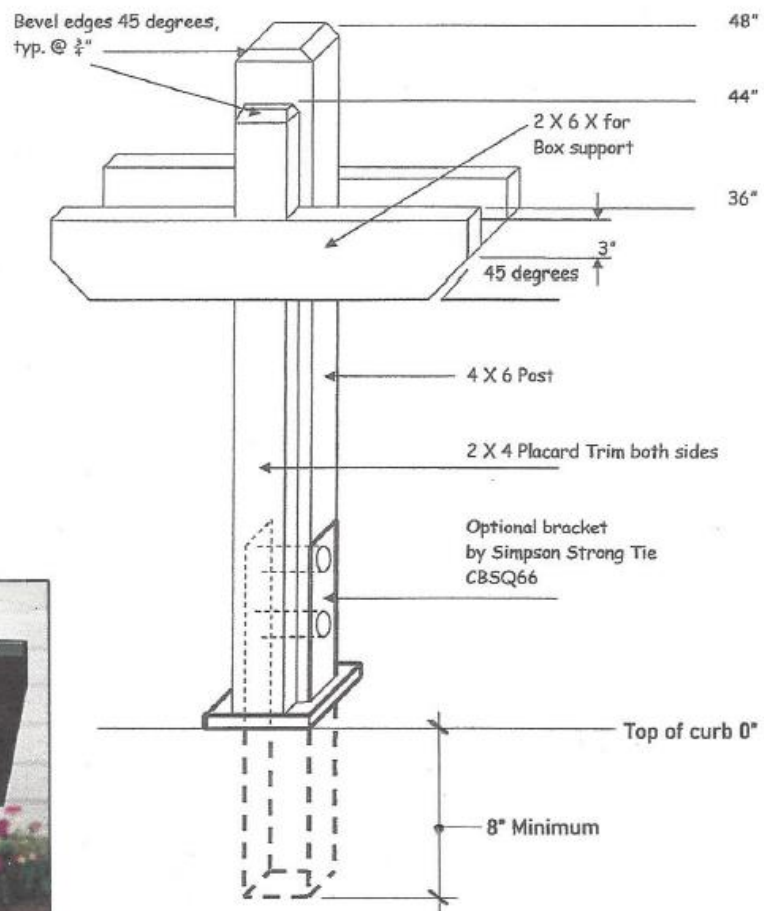

MAILBOX POST DETAIL

