

**BRITTANY LANDING THE BAY  
HOMEOWNERS' ASSOCIATION**

**ARCHITECTURAL RULES  
AND STANDARDS**

This document supersedes and replaces all previous Brittany Landing the Bay Architectural Rules and Standards & Landscape Guidelines.

Adopted: May 2021

## TABLE OF CONTENTS

### SECTION 1 ADMINISTRATIVE

Definitions.....	4
CC&R Compliance	
What you need to know before you improve, modify or plant almost anything..	5
Common Areas.....	6
Owners’/Tenants’ Responsibility	
Maintenance Agreements	

### SECTION 2 ARCHITECTURAL RULES AND STANDARDS

Prior Approval Required .....	7
Final Inspections Required	
Fast Track	

### SECTION 3 MODIFICATIONS

Address House Numbers, Lighted Fixture .....	8
Address House Numbers, Other	
Air Conditioners	
Ancillary (Freestanding) Structures.....	9
Antenna/Cable/Satellite Dish Installations	
Awnings & Exterior Sun Shades	
Backyard/Patio Improvements.....	10
Backyard/Patio Maintenance	
Balconies	
Barbecues and Fire Pits	
Decks	
Doors, Entry.....	11
Doors, Screen	
Doors, Utility Closet	
Electric Vehicle Charging Stations (EVC)	
Fences, Non-Party & Gates.....	12
Fences, Party	
Garage Doors, Wooden	
Garage Doors, Replacement.....	13
Hose Hangers	
Light Fixtures, Exterior on Residence	
Light Fixtures, Front Wall Mounted	
Light Fixture, Ceiling Mounted by Front Door	
Light Fixtures, Backyard, Patio and Balcony.....	14
Lights, Backyard/Patio, Walkway and Ground Landscape Lights	
Lights, Common Area, Walkway to Residence	
Skylights/Solar Tube Lights	

Solar Panel Installations  
 Sports and Exercise Apparatus  
 Stepping Stones in Common Area to Fence Gates and Utility Closet.....15  
 Surfaces in Backyard/Patio  
 Trees, Private Backyards  
 Utilities (Wires, Cable, Conduit and Plumbing)  
 Ventilation Devices.....16  
 Windows, Sliding and/or French Doors  
 Window Coverings

**APPENDIX**

Party Fence, Overlapping Style Specifications and Photo.....17  
 Party Fence, Non-Overlapping/Abutted Slat Style Specifications and Photos ....18  
 Address House Numbers, Placement Photos.....19  
 Building Paint and Entry Door Color Schemes.....20  
 Lattice Enclosure for A/C, Specifications and Photo .....21

## SECTION 1 - ADMINISTRATIVE

### Definitions:

- Association - Brittany Landing the Bay Homeowners' Association (BLB)
- CAC - Community Architectural Committee
- Community - Community of Harbor Bay Isle Owners' Association (CHBIOA)
- Board - Brittany Landing the Bay Homeowners' Association Board of Directors
- PAC - Brittany Landing the Bay Project Architectural Committee
- CC&Rs- CHBIOA and Brittany Landing the Bay Covenants, Conditions and Restrictions Documents

**CC&R Compliance:** When you purchased your home, you took title to your Lot subject to all restrictions, easements, rules, etc. that were recorded on your Lot as set forth in your Policy of Title Insurance. You also took title to your Lot subject to all of the provisions set forth in the Covenants, Conditions and Restrictions (CC&Rs) recorded on your property as set forth by the Community of Harbor Bay Isle Owner's Association (Community) and the Brittany Landing the Bay Homeowners' Association (Association or BLB). The BLB HOA, through its Board of Directors, will strictly enforce the CC&Rs to maintain the appearance of the community and minimize association expenses.

The CC&R's provide for architectural review through the Community Architectural Committee (CAC) and the Project Architectural Committee (PAC) for Brittany Landing Bay. While the PAC and CAC review exterior improvements for conformance to architectural guidelines, it is both the Community and Project Boards of Directors that enforce the CC&R's and Architectural Standards to maintain the appearance of BLB and other Community neighborhoods. These two boards may assess fines, after opportunity for public hearing, to homeowners who violate the CC&Rs and/or the Architectural Standards. Furthermore, unapproved installations may be subject to corrective measures or replacement of the non-conforming construction work at the homeowner's expense.

**What you need to know before you improve, modify or plant almost anything:**

1. Refer to BLB Association CC&Rs to determine whether an item is the responsibility of the Association or the homeowner. There are also lists included with the annual disclosures that attempt to clarify these responsibilities.

- Brittany Landing Bay – Maintenance Responsibilities of Association and Individual Residence (Townhouse) Owners
- Brittany Landing Bay – Maintenance Responsibilities of Association and Individual Residence (Condominium) Owners

*If there is a conflict between the lists and the CC&Rs, the CC&Rs prevail.*

*These documents are available in the Members Only, BLB Documents Section at [www.harborbay.org](http://www.harborbay.org).*

2. For owner maintained items, determine any rules, restrictions and guidelines regarding that item in the following documents:

- The *Community of Harbor Bay Isle CAC Architectural Rules and Standards & Plant Guidelines*.
- The *Brittany Landing the Bay Homeowners' Architectural Rules and Standards* (this document) which are more restrictive than CHBIOA's.

*Both documents can be accessed online @ [harborbay.org](http://harborbay.org) or obtained from the Association Manager at 510-865-3363.*

3. All building modifications (exterior and interior) must comply with applicable building codes and permits must be obtained when the code requires them.

*One example of an interior modification that requires a building permit is removal or modification of an interior wall.*

4. Although interior modifications do not go through the application process, there may be applicable CC&Rs that must be adhered to.

*For example, the BLB CC&Rs restrict alterations to flooring in upstairs condominiums.*

**Common Areas:** Common Areas are intended for ownership use by the Brittany Landing the Bay Homeowners' Association or by the Community of Harbor Bay Isle Owners' Association. Lagoons, private streets and non-private lot parcels are examples of Common Areas.

***Maintenance of Common Area is the sole responsibility of the Association. The Association alone can apply to improve, modify or do landscaping work in the Common Area. (See two exceptions listed below.)***

- A landscape contractor hired by the Board of Directors performs the work. Homeowners are not to interfere with the work of contractors.
- Any plant in the Common Area becomes part of the Common Area and will be maintained by the Association.
- Residents are not to place pots, or other personal items, on the soil of the Common Area.
- Any modification may be moved and/or removed at any time without notice.
- Trees in the Common Area are a major asset of the Association. Each one is tagged with a number and maintained solely by a Tree Company or Landscape Contractor hired by the Board. Any trimming or removal of community trees in the Common Area may be considered vandalism and depending upon the value of the tree may be a felony. The Board may consider restitution or fines.
- Two homeowner modifications are allowed to be made in the Common Area and require an architectural application. See the following items in the next section.
  - Lights, Solar, Common Area, Walkway to Residence
  - Stepping Stones in Common Area to Fence Gates and Utility Closet

**Owners'/Tenants' Responsibility:** Owners are accountable and responsible for the consequences of their tenants' activities.

**Maintenance Agreements:** Maintenance Agreements (MA) are required for installation of an item that may effect the integrity of Association Property. Any subsequent damage to Association Property related to installation of a homeowner modification is the responsibility of the homeowner. Modifications requiring Maintenance Agreements are identified in Section 3 of this document.

***An example of homeowner responsibility would be water damage or water intrusion that may be related to the replacement of windows or sliding glass doors that damages Association Property.***

## SECTION 2 - ARCHITECTURAL RULES AND STANDARDS

This section provides an overview of procedures. Refer to Community documents for detailed procedures and Community rules at [www.harborbay.org](http://www.harborbay.org).

**Prior Approval Required:** Refer to *CHBIOA CAC Architectural Rules and Standards*. The following is the short version, as it applies to our Association. Architectural Applications and plans must be submitted to Architectural Services and approved by the PAC and the CAC prior to commencing property modification or landscaping projects.

- Architectural Applications are available through the CHBIOA Offices or on-line at [www.harborbay.org](http://www.harborbay.org).
- Check the Community Architectural Committee's Meeting Schedule on the back page of the Architectural Application or the CHBIOA web site.
- The Architectural Services Manager is available (510-865-3363) to help you with the application and plan review process.
- Homeowners are encouraged to provide their contractor with a copy of the CHBIOA application approval letter to confirm that the approved construction materials and products are those contained in the owner/contractor agreement.

***Approval of a prior application does not set precedent for subsequent applications.***

**Final Inspections Required:** Applications approved by the CAC are valid for one year. Owners must complete the work and request a Final Inspection of their installation from the Architectural Services Manager before the application expires. Architectural application approval is a design review only. Final inspection is to approve for appearance, not for structural integrity.

**Fast Track Applications:** See *CHBIOA CAC Architectural Rules and Standards* for items that may be fast tracked. In addition to those items, the Architectural Services Manager has the Board's approval to fast track the following architectural items.

- Garage Door replacement
- Utility Door replacement
- Entry Door re-painting
- Address House Numbers, Lighted Fixture
- Address House Numbers, Other

## SECTION 3 - MODIFICATIONS

This section lists modifications where BLB has additional and/or more specific rules or guidelines than the *CHBIOA CAC Architectural Rules and Standards*. An Architectural Application is required unless otherwise indicated.

### Address House Numbers, Lighted Fixture:

- Lighted street address numbers, by the garage, are a homeowner responsibility. Replacement must be like for like.

### Address House Numbers, Other:

- Homeowners may affix house numbers on trim near front door. Only metal or plastic numbers in brushed silver, black, brass or oil-rubbed bronze no taller than 6" are acceptable.
- See Appendix for photos of sample locations.
- Street address curb painting is not permitted.

### Air Conditioners: Refer to *CHBIOA CAC Architectural Rules and Standards*

Homeowners considering installation of A/C are encouraged to be aware of the comparative advantages and/or disadvantages of the two types of A/C systems available. A ducted system delivers A/C through the existing forced air heating ducts with an outdoor condenser connected to the existing furnace. A ductless system delivers A/C through individual room air handlers directly from an outdoor condenser and does not require connection to an existing furnace and ducting system.

Installation of an A/C Unit in homeowner's private backyard/patio will be considered on a case-by-case basis by the BLB Board with particular attention to placement and the following guidelines.

- Sound level may not exceed 56 decibels.
- A/C Condenser Unit must be placed on and attached to a 3" concrete base.
- Unit must be a minimum of 12" from any building and 6" from any fence.
- Detailed drawing of any line set must be included with the application and approved by the Board specifically as drawn.
- Any place the siding is pierced must be caulked and watertight.
- Any exterior connections must be painted to match the siding or trim to which they are attached.
- Unit must be screened from view from any public walkway.

**Maintenance Agreement required**



Installation of an A/C Unit in the Common Area will be considered on a case-by-case basis for upper condominium homeowners only by the BLB Board with particular attention to placement and the following guidelines.

- Sound level may not exceed 56 decibels.
- A/C Condenser Unit must be placed on and attached to a 3" concrete base.
- Unit must be a minimum of 12" from any building and 6" from any fence.
- Detailed drawing of any line set must be included with the application and approved by the Board specifically as drawn.
- Any place the siding is pierced must be caulked and watertight.
- Any exterior connections must be painted to match the siding or trim to which they are attached.
- The unit must be enclosed by lattice structure painted to match the siding that is a minimum of 12" from any building. The structure must extend 6" from all sides of the unit and be equal to the final height of the unit on the concrete pad. The structure must be wholly on the common area dirt.
- See Appendix for specifications and photo.
- Homeowner will pay for any modifications to existing irrigation system required by placement of A/C unit and enclosure.
- Homeowner will pay for any modifications to existing plants as required for placement of A/C unit and enclosure and/or as required by manufacturer and building codes. Removal and/or installation of replacement plants will be done by BLB Landscaping contractor with recommendations made by BLB Landscape Committee to the Board.

#### **Maintenance Agreement required**

**Ancillary (Freestanding) Structures:** Refer to *CHBIOA CAC Architectural Rules and Standards*. Be sure to see information on specific types of structures such as Ancillary, Arbors, Arches, Gazebos and Sheds.

**Antennae/Cable/Satellite Dish Installations:** Refer to *CHBIOA CAC Architectural Rules and Standards*.

- Care must be taken to not damage the siding.
- See specific information in *CHBIOA's Antennae/Cable/Satellite Dish Installations section, Group #2* regarding Townhouse and/or Condominium Project Associations recommended priority order of installation sites.
- See also section on Utilities (Wires, Cable, Conduit and Plumbing), in this document, for information on installation of wires.

#### **Maintenance Agreement required**

#### **Awnings & Exterior Sun Shades:**

Exterior fixed awnings, retractable awnings (canopies) and other sun shading devices attached to exterior walls of dwellings are not permitted.

**Backyard/Patio Improvements:** Refer to *CHBIOA CAC Architectural Rules and Standards*, Plant Guidelines Section, to understand our Community's unique conditions, design intent, our Urban Forest and specific requirements that apply to landscaping improvements. Also refer to BLB Plant Palette for suggestions.

- Mulch must conform to *CHBIOA Plant Guidelines*.
- Owners are responsible for the consequences of any landscape material they install in their yards.

**Backyard/Patio Maintenance:** Owners are responsible for maintaining their private landscaping (enclosed portion of residential lots) in a healthy and attractive condition. Ground plants, furnishings and fixtures visible to neighboring property, or public areas, shall be maintained in good condition.

**Balconies:** Owners are responsible for keeping their balcony in a clean and orderly condition. Potted plants and furnishings visible to neighboring property, or public area, shall be kept in good condition.

- The Association is responsible for the repair and replacement of the entire Condominium balcony structure and the associated waterproofing system.
- Townhouse owners are responsible for everything but railings. Replacement is like for like.
- If a townhouse owner replaces the structure of the balcony an Architectural Application and City of Alameda Building Permit are required.

**Maintenance Agreement required**

**Specifically, *Covenants Regarding Construction and Maintenance of Improvements on Real Property, the document created to address structural balcony repairs and/or replacement, must be signed.***

**Barbecues and Fire Pits:** For permanent installation, these must be lower than the fence height and located in an area that will not permit smoke to unreasonably intrude into neighboring property.

**Decks:** Refer to *CHBIOA CAC Architectural Rules and Standards*.

- There should be sufficient space between the deck and fences or buildings to allow for drainage.
- Weed control must be maintained beneath the deck.
- Original storm drain access points under or around decks must continue to function as designed and remain accessible for Association maintenance purposes.

**Doors, Front Entry:** Maintenance and door replacement are the responsibility of the homeowner.

- Doors must fit into existing envelope and be wood framed.
- Doors may be wood, fiberglass or steel of any design.
- Windows in doors are allowed and may be of any size, shape, location and clarity; colored glass is not allowed.
- Doors may be natural stained wood-tone or painted in semi-gloss. See approved entry door colors in Appendix at the end of this document.
- Any replacement trim must be painted to match existing trim color for project to be considered complete. See Appendix for building color schemes.

**Doors, Screen:** Screen doors are permitted and may be a natural stained wood tone, white vinyl or the same color as the front door. Retractable screen doors are allowed as are metal security doors in approved entry door color schemes.

**Doors, Utility Closet:** Homeowner is responsible for frame and door.

- Replace like for like.
- Paint door the same color as siding.
- Any replacement trim must be painted to match existing trim color for project to be considered complete.
- See Appendix for building color schemes.
- Non locking door knob

**Electric Vehicle Charging Stations (EVC):** Stations installed in garages do not require an Architectural Application or Maintenance Agreement to be completed. Vehicles may be charged in exclusive use Common Area driveways from a station installed in the garage. Charging cords are not permitted on Common Area landscape, walkways, sidewalks, or streets.

**Stations installed in exclusive use Common Areas or private parking spaces** require the following:

- Architectural Application must include detailed plans including specification clearly indicating where the EVC will be located, the brand or manufacturer, technical specifications, and dimensions (i.e., height, width, weight etc.) as well as structural requirements.
- A licensed contractor must be used to install the EVC.
- Within 14 days of approval, provide a certificate of insurance that names BLB as an additional insured under your insurance liability coverage policy in the amount of \$1,000,000 and shall name BLB as an additional insured under the policy with the right of notice of cancellation.
- The owner will pay for all electrical usage associated with EVC.

- The owner and each successive owner of the EVC, always, shall maintain a homeowner liability coverage policy in the amount of \$1,000,000 and shall name BLB as a named insured under the policy and a right of notice of cancellation.

**Maintenance Agreement required for any installation other than in garage.**

An EVC Station Maintenance Agreement will state that the homeowner and each successive homeowner of the EVC shall be responsible for the following:

- Costs of damage to the EVC, Common Areas, exclusive use common area or separate interests resulting from the installation, maintenance, repair, removal, or replacement of the EVC.
- Cost of the maintenance, repair, and replacement of the EVC until it has been removed and the restoration of the Common Area after removal.
- The cost of electricity associated with the EVC.
- Disclosure to prospective buyers the existence of EVC Maintenance Agreement.

**Fences, Non-Party & Gates:** All fences that are not party fences are the responsibility of the Association. This includes all condominium fences. For townhouses, this includes the back fence and the unit fence with its wooden gates. See exception below:

*Some townhouse backyard metal fences have metal gates. This gate and its two adjacent pressure treated 4" x 4" wood posts are the responsibility of the homeowner.*

**Fences, Party:** Per *BLB CC&Rs*, these fences, between the backyards of townhouses, are the combined responsibility of the adjacent homeowners.

- They may be of overlapping or non overlapping/abutted slat style in cedar or redwood with pressure treated 4"x 4" posts set in cement.
- Bottom piece should be pressure treated wood.
- Fence height is like for like.
- See Appendix for specifications and photos.

**Garage Doors, Wooden:** Refer to *CHBIOA Architectural Rules and Standards*. The Association is responsible only for the surface or *skin* of the original wood doors.

- Raised trim on the door may be repaired or replaced without an Architectural Application.
- When wood panels are in distressed condition the door must be replaced with a roll-up or lift-up metal door.
- Any replacement trim on the building must be painted to match existing trim color for project to be considered complete. See Appendix for building color schemes.

**Garage Doors, Replacement:** Refer to *CHBIOA CAC Architectural Rules and Standards*.

- For consistency, only a lift-up or roll-up galvanized steel door in a standard white color is allowed.
- Owners are responsible for maintaining and painting metal doors.
- Door pattern must be wood grained short panels: four across for single car garages or 8 across for double car garages.
- Any replacement trim on the building must be painted to match existing trim color for project to be considered complete. See Appendix for building color schemes.
- Windows are permitted in the top row only, must be opaque, and match the design below:



**Hose Hangers:** A hose hanger may not be attached to the building but hose may be stored neatly near or on hose bib. A free standing hose holder is allowed.

**Light Fixtures, Exterior on Residence:** Refer to *CHBIOA CAC Architectural Rules and Standards*. Light fixtures must be replaced in the same location as original. Installation is not considered complete until installation site is caulked and painted. Motion detection lights are allowed. See Appendix for building color schemes.

**Maintenance Agreement required**

**Light Fixtures, Front Wall Mounted:**

- Lantern style, black or oil rubbed bronze finish with non-clear glass
- Size: Approximately 8" length and 6" width, length not to exceed 12"
- For upstairs condominiums and two-bedroom townhouses, both front wall mounted light fixtures must be the same. Downstairs condos have only one front light and it does not need to match the lights controlled by the upstairs condo.

**Light Fixture, Ceiling Mounted by Front Door:**

- Flush mounted black or oil rubbed bronze finish with non-clear glass.
- Size: Approximately 8" width and 4" height. Width not to exceed 12".

**Light Fixtures, Backyard, Patio and Balcony:**

- Black, silver or oil rubbed bronze finish with non-clear glass.

Examples



**Lights, Backyard/Patio, Walkway and Ground Landscape Lights:** Refer to *CHBIOA Architectural Rules and Standards*. To be approved, wired lights must meet the following guidelines:

- UL Approved and must be powered via a Ground Fault Detector outlet circuit
- Wiring must be concealed
- Low wattage design
- Fixtures must be black or oil rubbed bronze finish
- Electrical work must comply with relevant codes

**Lights, Common Area, Walkway to Residence:** The Board recognizes the safety advantage of lighting sidewalks and steps to a homeowner’s front door in the Common Area and is allowing owner installation as follows:

- Solar lights, black or oil rubbed bronze in color, no taller than 18 inches will be allowed.
- Lights must not interfere with landscaping and irrigation system. All walkway lights must be identical.
- The Board may require such solar lights to be moved or removed at any time for any reason.

**Skylights/Solar Tube Lights:** Refer to *CHBIOA CAC Architectural Rules and Standards*.  
Maintenance Agreement required

**Solar Panel Installations:** Refer to *CHBIOA CAC Architectural Rules and Standards*.  
Maintenance Agreement required.

**Sports and Exercise Apparatus:** Permanent sports and exercise apparatus installations, which may be viewed at ground level, above the fence, are not permitted.

### **Stepping Stones in Common Area to Fence Gates and Utility Closet:**

- BLB uses 12" x 12" cement stepping stones to gates in fences and utility closets.
- They may be replaced by 12" square or round stepping stones in cement or natural stone in gray, brown, buff or earth-tone colors; designs are allowed.
- Placement of stepping stones may not interfere with drip system and may be set in wood mulch only.

### **Surfaces in Backyard/Patio:** Refer to *CHBIOA CAC Architectural Rules and Standards*.

- Acceptable backyard patio surfaces may be in concrete (brushed neutral or earth tones), aggregate concrete mix, brick, or natural stone (gray, brown, buff or earth-tones).
- Painted or colored coatings are prohibited, except for a clear sealer.
- A clearance of at least 6 inches must be maintained between patio surfaces and fences.

### **Trees, Private Backyards:**

- Consider potential mature height and width of trees and shrubs. For lower-level condos, trees and shrubs need to be kept lower than bottom of balcony; about 10 feet. For townhomes, trees and shrubs need to be kept no higher than 20-25 feet.
- Tree branches must not touch or overhang roofs.
- Trees shall not be planted closer than 3 feet to fences and buildings. Homeowners will be responsible for any damage to fences, buildings or the Common Area and required to reimburse BLB and/or any other impacted party for any required repairs caused by trees in their private backyard.
- Trees shall not unduly interfere with neighboring property, yards or views.
- For suggested species of trees, see *CHBIOA Plant Guidelines*.
- Trees shall be maintained in a healthy condition. Trees may become overgrown for their location. Once a tree stands taller than the roof eaves of adjacent homes, the status of the tree will be reviewed by the Board and trimming or removal may be required.

### **Utilities (Wires, Cable, Conduit and Plumbing):**

- BLB siding is Hardie Board fiber cement.
- Run wires below the edge of the Hardie Board lateral siding board and/or up the side of the wood trim.
- Wires/conduits must be painted to match the area to which they are attached.

### **Maintenance Agreement required**

**Ventilation Devices:** Refer to *CHBIOA CAC Architectural Rules and Standards*.

Metal flues, vents and exhaust fans installed by Owners in Common Area roof must be painted to match the existing roof color.

*For example, to vent new bathroom fan.*

**Maintenance Agreement required**

**Windows, Sliding and/or French Doors:** Refer to *CHBIOA CAC Architectural Rules and Standards*.

- Replacement windows, sliding glass doors shall be white vinyl.
- Any replacement trim must be painted to match existing trim color for project to be considered complete. See Appendix for trim color
- French Doors may be painted to match existing trim color. See Appendix for Trim color.

**Maintenance Agreement required**

**Window Coverings:** See *BLB CC&Rs* regarding restrictions on Windows Coverings.

Windows coverings must consist of shutters, draperies or blinds in white, off white or natural wood.



## APPENDIX

### PARTY FENCE, OVERLAPPING STYLE SPECIFICATIONS AND PHOTO

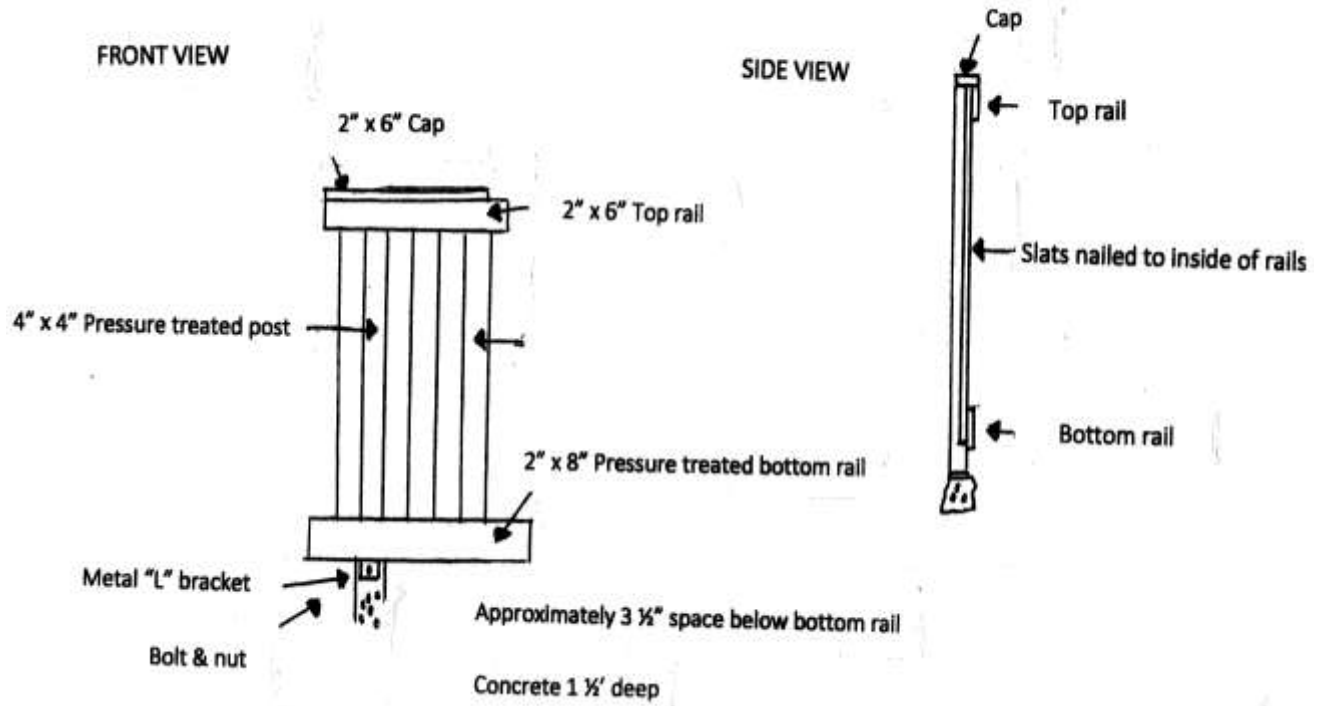

PARTY FENCE, NON-OVERLAPPING/ABUTTED SLAT STYLE SPECIFICATIONS AND PHOTOS

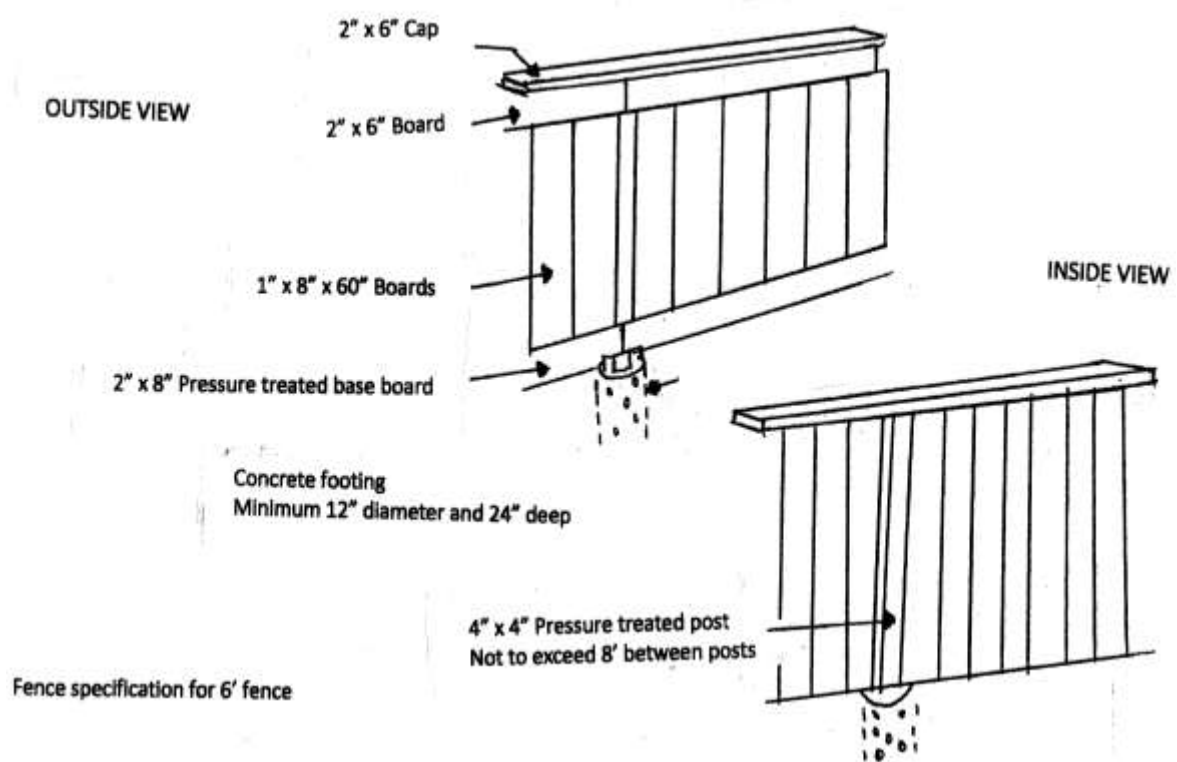

ADDRESS HOUSE NUMBERS, PLACEMENT PHOTOS



## BUILDING PAINT COLOR SCHEMES

2020 Paint Scheme (KM denotes Kelly Moore Paint)

### 1. Blue/Green Color Scheme

Body/Siding	KM4832-2	Marble Green	1245 Low Sheen
Accent Trim	KM4833-3	Camping Trip	1250 Semi-Gloss
Trim	23	Swiss Coffee	1250 Semi-Gloss

### 2. Taupe Color Scheme

Body/Siding	KM4594-2	Bay Area	1245 Low Sheen
Accent Trim	KM4595-3	Clay Bath	1250 Semi-Gloss
Trim	23	Swiss Coffee	1250 Semi-Gloss

### 3. Gray Color Scheme

Body/Siding	KM5825-3	Not My Fault	1245 Low Sheen
Accent Trim	KM5823-2	City Tower	1250 Semi-Gloss
Trim	23	Swiss Coffee	1250 Semi-Gloss

### 4. Cream Color Scheme

Body/Siding	KM5710-1	Sunday Drive	1245 Low Sheen
Trim	23	Swiss Coffee	1250 Semi-Gloss

## ENTRY DOOR COLORS

### 1. Doors, Entry

Doors may be **natural stained woodtone** or one of the following colors:

White	23	Swiss Coffee	1250 Semi-Gloss
Red	KM5506-5	Fire Chi	1250 Semi-Gloss
Blue	KM5016-5	Water Chi	1250 Semi-Gloss
Eggplant	KM5576-5	Polka Dot Plum	1250 Semi-Gloss
Charcoal	KM4883-5	Black Cat	1250 Semi-Gloss

*Other brands of paint are acceptable as long as the paint is semi-gloss and color matched to one of these five.*

## LATTICE ENCLOSURE FOR A/C SPECIFICATIONS AND PHOTO

Actual dimensions will depend upon placement and size of unit.



### Specifications for a 2 or 3-sided A/C Lattice Enclosure in the Common Area

- The structure will be open to the building and have 2 or 3 sides, depending upon placement.
- Four 4"x4" pressure treated posts will be set in cement above grade level in the dirt portion of the Common Area for a 3-sided enclosure/three posts for a 2-sided enclosure. Posts will be set a minimum of 12" from any building and 6" away from all sides of the A/C unit.
- 2x4's will frame a horizontal/vertical design lattice. The 2x4's and lattice may be wood, pressure treated wood or a resin composite. No portion of the structure will touch the dirt or overhang the sidewalk.
- The final structure will be the height of the A/C unit on the cement pad and painted to match the siding.
- Homeowners may want to consider removable lattice sections, attached with bolts, on the sides of the A/C Unit that need to be accessible for maintenance.