

# LANTERN BAY

## Approved Locking Mailbox



[www.lockingmailbox.com](http://www.lockingmailbox.com)

Approved in Black and Standard Size Only

### The "Pinnacle"

The Pinnacle locking mailbox secures incoming mail to safeguard your personal information. Designed to comply with postal regulations.

### Product Specifications

Standard – Regular Duty: Item # 1022, 1/13" plate

Standard – Heavy Duty: Item # 1025, 3/16" plate

Dimensions: 10.75"W x 11"H x 23"D

Color: Black



# MAILBOX POST INSTALLATIONS FOR LANTERN BAY HOA

TO BE USED FOR SOLAR LOCKING MAILBOXES

## SINGLE BOX CONFIGURATION

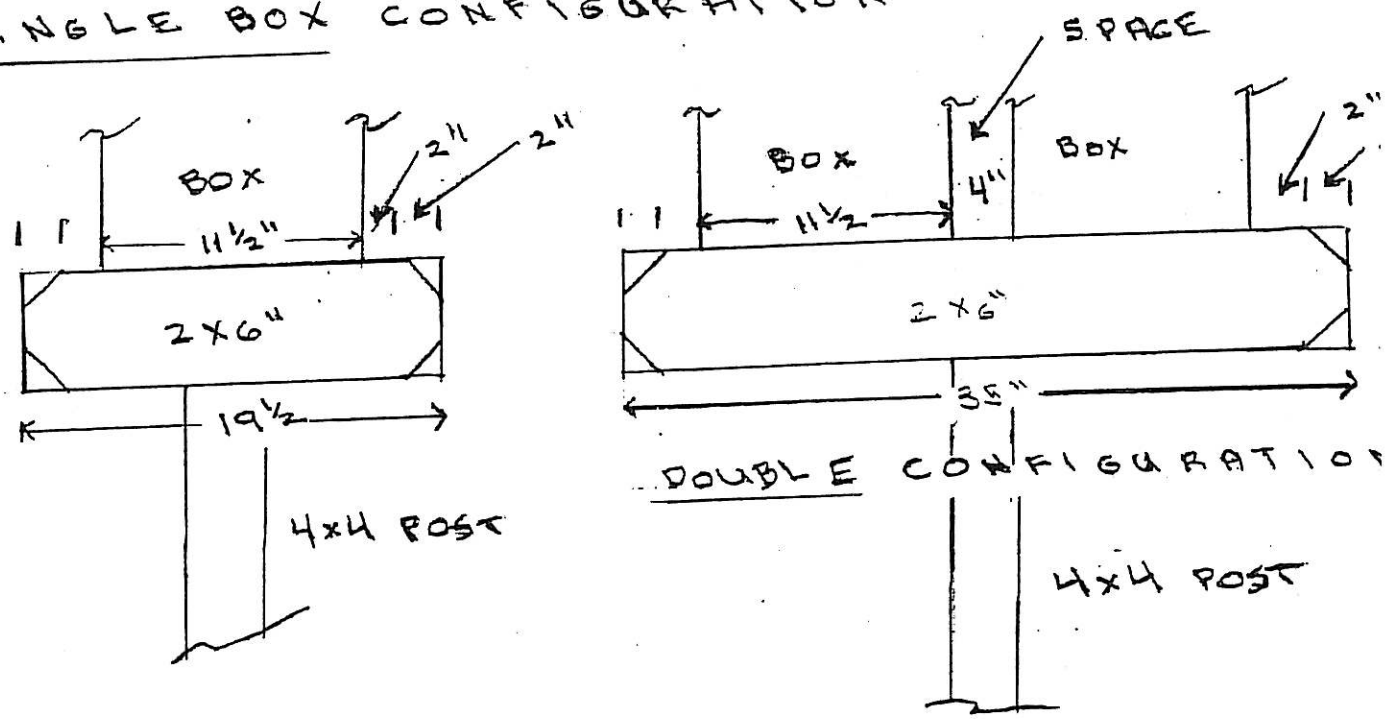

## TRIPLE CONFIGURATION

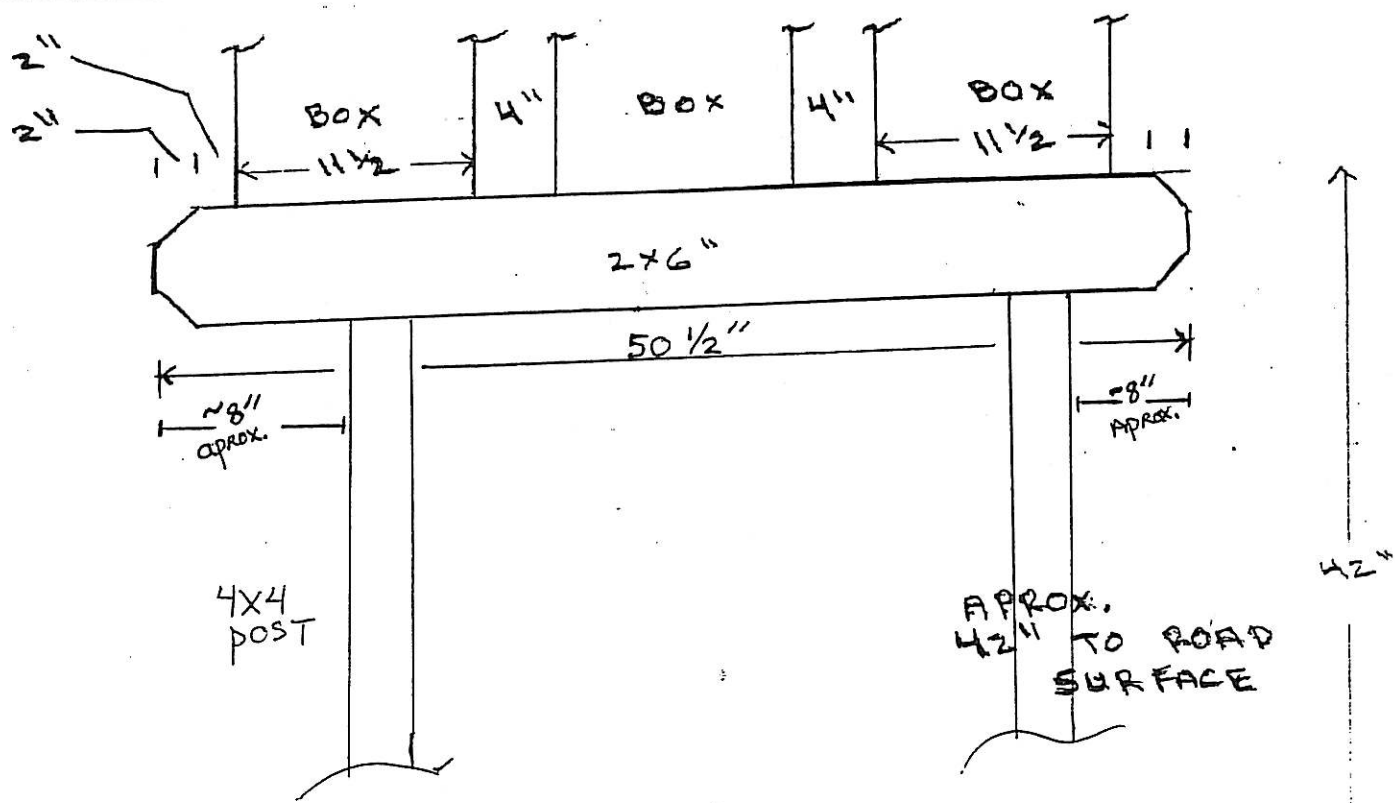

4 BOX 2 POST INSTALLATION

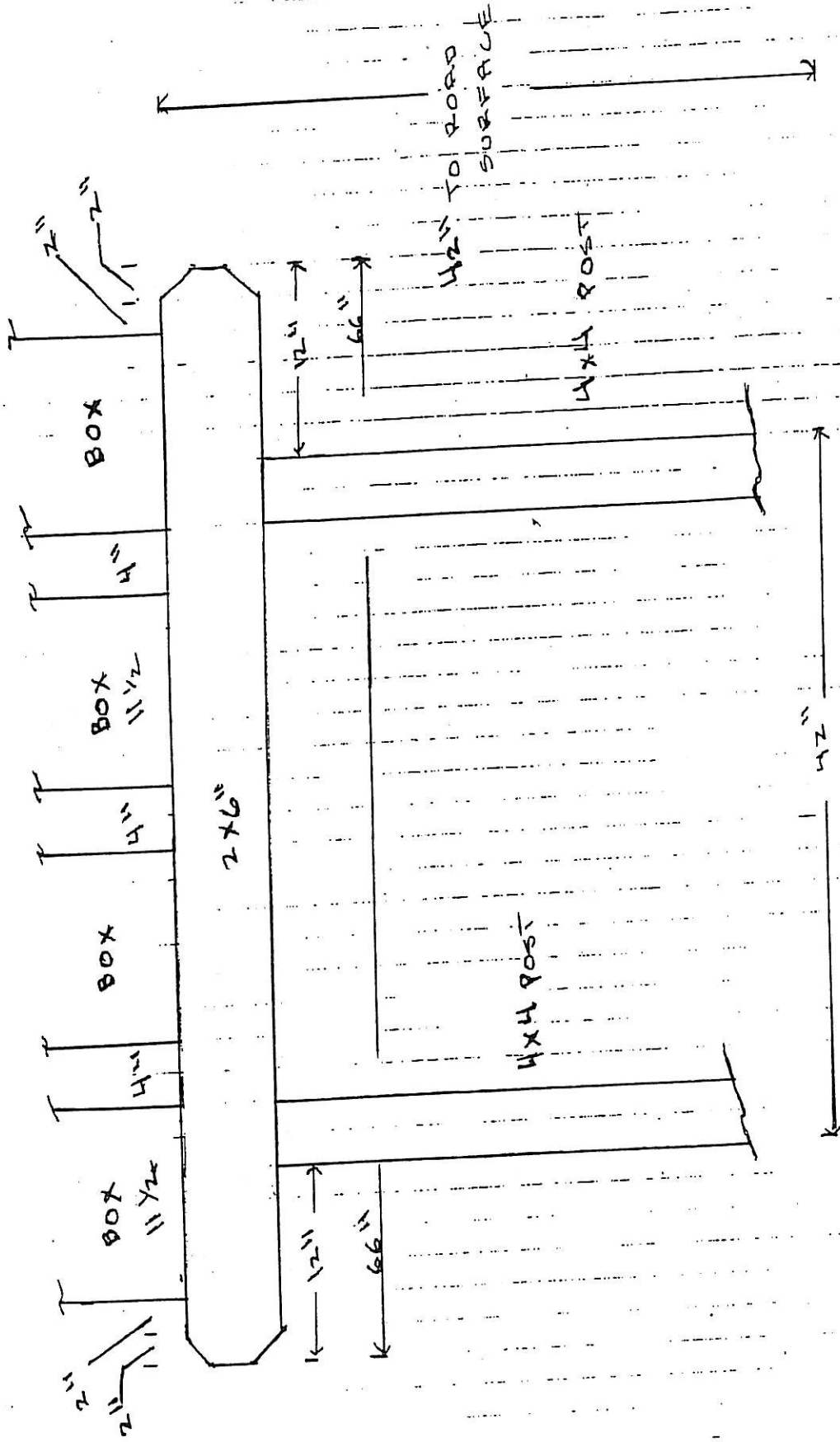

POSTS - 4"x4" REDWOOD, PRESSURE TREATED OR "EXROTENTIAL"

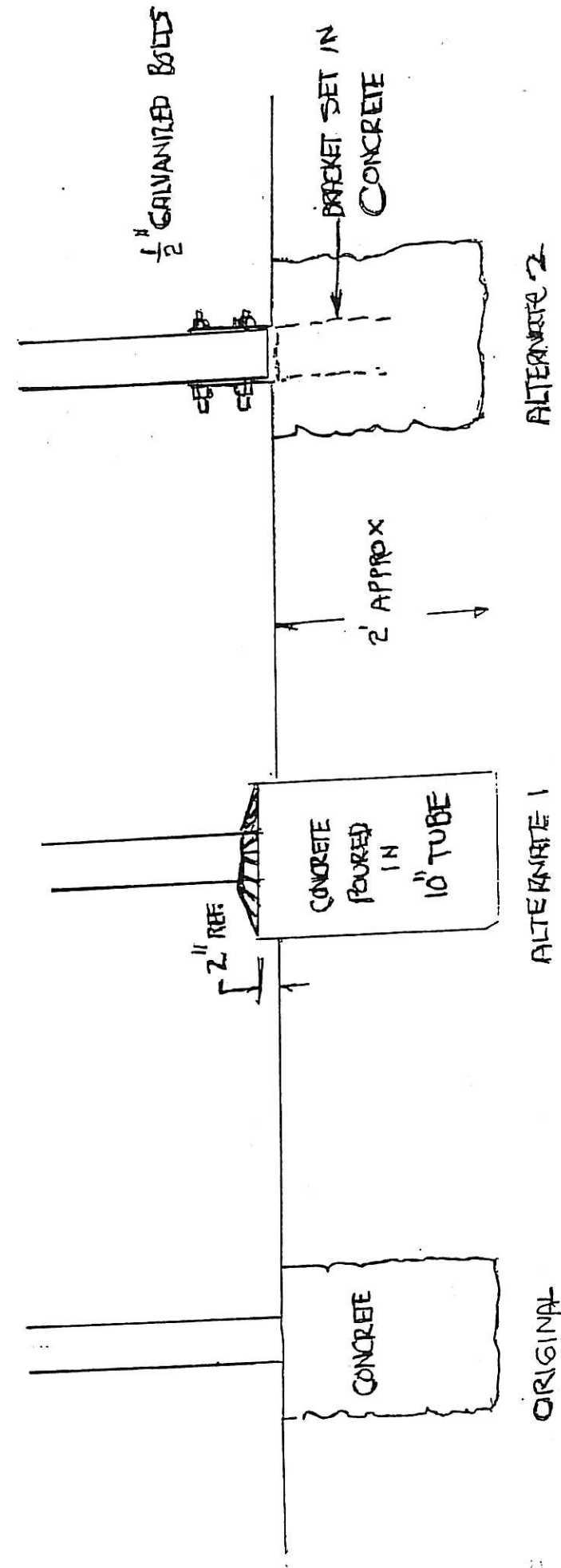

# LANTERN BAY