

BAY COLONY
Approved Locking Mailbox



www.gibraltarmailboxes.com
Approved in Black Only

Curbside MailSafe

Mailbox is constructed from steel and high impact polymer. A concealed locking access door keeps correspondence from being lost or stolen. For incoming and outgoing mail.

Product Specifications

Dimensions: 13.25" W x 9.5" H x 24" D

Weight: 14.5 lbs

Model: RSKB0000

Color: Black



BAY COLONY

Mailbox Post Installation Guidelines

To be used with the approved Solar Group Curbside MailSafe locking mailbox.

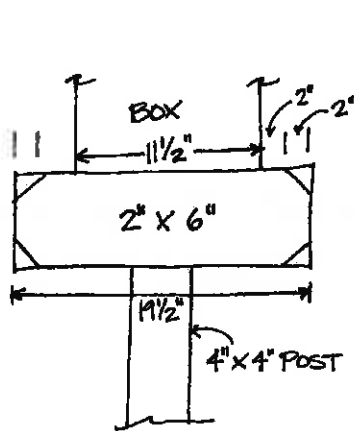

Single Box Configuration

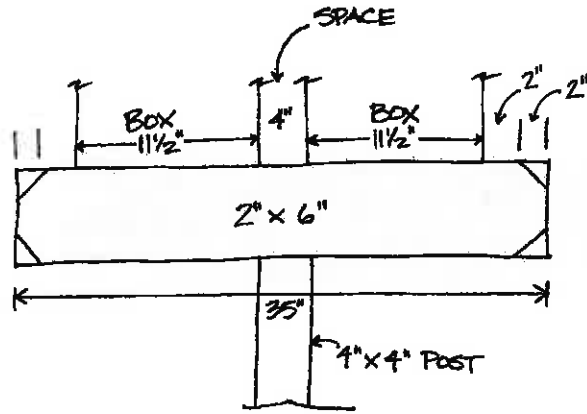

Double Box Configuration

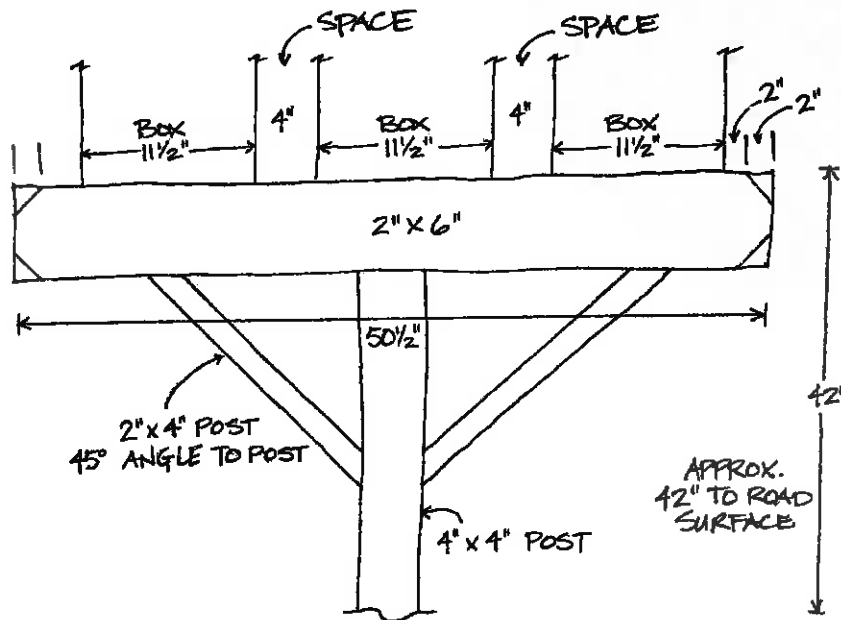

Triple Box Configuration