



Approved by the Board of Directors  
August 28, 2003

## The Pinnacle Mailbox™

*"When you buy a Pinnacle Mailbox, you are  
buying quality for life."*

Mail theft is a growing problem throughout the United States. One of the most effective ways to prevent mail theft, is to use a locking mailbox. There are a number of locking mailboxes in the market today, but no other locking mailbox has been designed to meet the security needs of both the homeowner and mail carriers better than The Pinnacle Mailbox™.

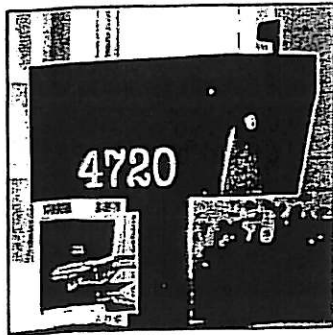

- Standard Size Dimensions:
  - Pinnacle  
10.75" W x 11"H x 23" D
  - Pinnacle Plus  
11"W x 11"H x 23" D

### Homeowners

When it comes to appearance, the Pinnacle has no equal. Our Pinnacle Plus models are made from aluminum plate 3/16" thick, making them *dent proof* and *baseball bat resistant*. This is 3 times thicker than most other locking mailboxes.

Three reasons that make The Pinnacle Mailbox the "best" locking mailbox are *Security, Durability, and Affordability*.

### Features

#### Security

- Security flap keeps incoming mail secure, and you keep the keys.
- Large enough to hold several days of mail without overfilling.

#### Durability

- All reinforced aluminum construction makes the Pinnacle 100% Rust Free.
- Environmentally safe powder coat finish protects color for years.

Secure Online Ordering or



Call:

Toll Free @1-877-YOU-GUARD (968-4827)

Business Hours: M-F 8:00 AM-4:30 PM PST

Website: [www.lockingmailbox.com](http://www.lockingmailbox.com)

# USPS APPROVED

BAYVIEW HARBOR

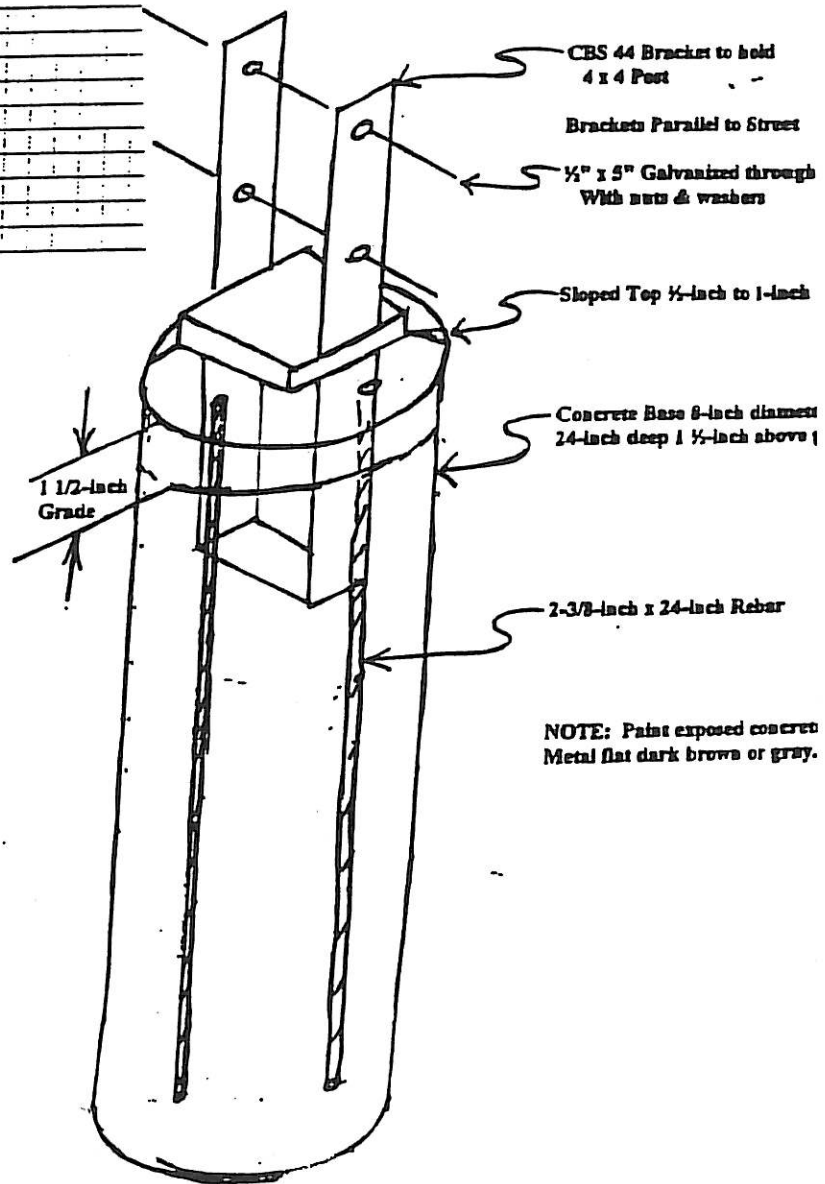
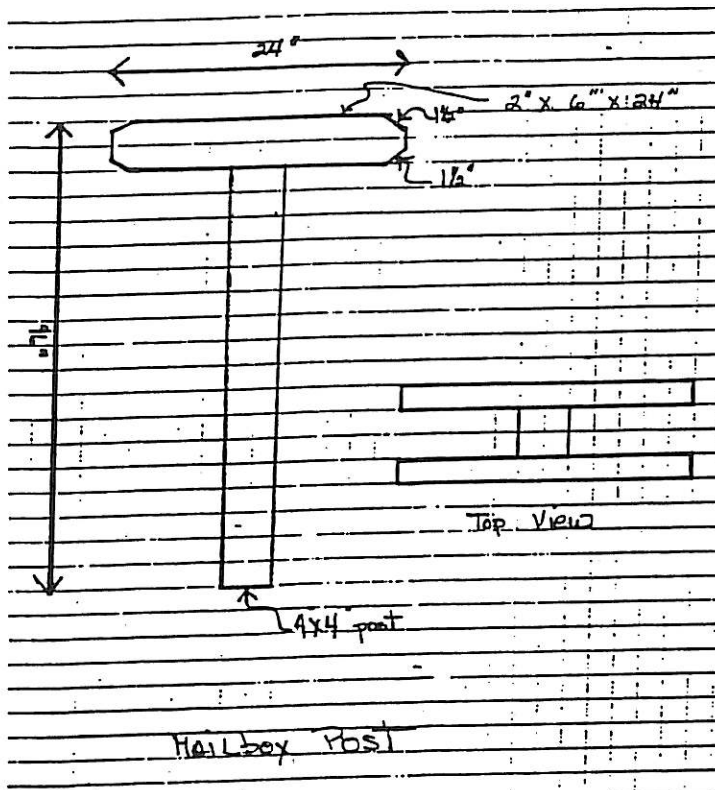

NOTE: Paint exposed concrete Metal flat dark brown or gray.

RESOLUTION: # 99-02

DATE: October 12, 1999

**RESOLUTION  
OF THE BOARD OF DIRECTORS  
BAYVIEW HARBOR HOME HOMEOWNERS' ASSOCIATION  
"MAILBOX REPLACEMENT &  
MAILBOX POST INSTALLATION POLICY"**

**WHEREAS**, the Board of Directors for the Bayview Harbor Homes Homeowners' Association is committed to maintaining property value and a common code of conduct and order throughout the Association; and

**WHEREAS**, a common code of conduct and order requires establishing and distributing rule, regulations and guidelines; and

**WHEREAS**, the Association's Covenants, Conditions and Restrictions empower the Board of Directors to adopt Rules, Regulations and Guidelines for the orderly governance and good of all members; and

**THEREFORE, LET IT BE RESOLVED**, that any homeowner at Bayview Harbor Homes that intends to replace their mailbox post, must comply with the following requirements:

1. Mailboxes are to be black in color and standard rural post office certified.
2. If house numbers are placed on the mailbox, the number shall be one (1) inch in height and white reflective and placed on the door of the mailbox.
3. The mailbox post must be redwood lumber.
4. The mailbox posts are to be installed per the dimensions shown on the attached drawings.
5. The mailbox post must remain natural or a clear wood preservative can be applied.
6. Cement pads are to follow the directions shown on the attached drawing.
7. Brackets are to be placed parallel to the street.
8. Homeowners are responsible for all engineering necessary to ensure structural and functional integrity.

This Resolution is adopted and made part of the minutes of the membership meeting on October 12, 1999.

[OVER]